

# DESERT EXPEDITIONS

By Tom Sheppard, MBE, ARPS

**3rd Edition - June 1988**

1st Edition - February 1982

2nd Edition - March 1984

**ISBN 0-907649-15- 7**

**Published by the Expedition Advisory Centre**

Royal Geographical Society

(with the Institute of British Geographers)

1 Kensington Gore, London

SW7 2AR,UK

Tel. +44 (0) 20 7591 3030

Fax. +44 (0) 20 7591 3031

Email: [eac@rgs.org](mailto:eac@rgs.org)

Website: [www.rgs.org/eac](http://www.rgs.org/eac)

## CONTENTS

### SECTION 1: PLANNING CRITERIA

- 1.1 Main Criteria
- 1.2 Government Permission
- 1.3 Golden Rules
- 1.4 Logistics
- 1.5 Equipment
- 1.6 Personnel
- 1.7 Cost
- 1.8 Time

### SECTION 2: EQUIPMENT

- 2.1 Overall Considerations and Weight
- 2.2 Liquid Containers
- 2.3 Cooking Equipment
- 2.4 Camping Gear
- 2.5 Heliographs/Miniflares
- 2.6 Personal Kit
- 2.7 Appearance
- 2.8 Keeping Comfortable
- 2.9 'Office' Equipment
- 2.10 Other Equipment Lists
- Annex A: Personal Kit
- Annex B: Office Kit

### SECTION 3: VEHICLES FOR DESERT TERRAIN

- 3.1 Main Criteria for Choice
- Annex A: Ground Clearance and Associated Geometry
- Annex B: Load Distribution and Lashing

### SECTION 4: FUEL, WATER AND FOOD

- 4.1 Fuel
- 4.2 Water
- 4.3 Food
- Annex: Cooking Gear and Food

### SECTION 5: PERSONNEL AND TRAINING

- 5.1 Aim
- 5.2 Personnel Selection
- 5.3 Training
- 5.4 En Route Routine
- Annex A: Interview Marking Schedule

### SECTION 6: DRIVING AND RECOVERY

- 6.1 Overall Philosophy
- 6.2 Gearbox Transmission
- 6.3 Suspension affects traction
- 6.4 Transmission Brakes
- 6.5 Slippery Conditions, Poor Traction, Slopes
- 6.6 Obstacles, Recce, and Marshalling

6.7	Flotation on Sand or Salt Flat
6.8	Corrugations
6.9	Water
6.10	Recovery Methods
6.11	Turbo Diesels - Stopping
6.12	Training
Annex A:	Use of Land ladders
Annex B:	Tandem tow recovery method
Annex C:	Sand ladder table
6.13	Driver training programme

## **SECTION 7: PHOTOGRAPHY**

7.1	Cine Filming
7.2	Report (1975 Expedition)
7.3	Still Photography
Annex A:	Cine and sound Equipment
Annex B:	Still photography equipment

## **SECTION 8: VEHICLE MAINTENANCE AND TOOLS**

8.1	Philosophy - Preventive Maintenance
8.2	The Expedition Mechanic
8.3	Pre-Expedition Preparation
8.4	Nightly Inspection
8.5	Tools and Repair Kit
8.6	Spares
8.7	Fuel Consumption and Records
8.8	Cleanliness
Annex A:	End of day inspection – 1-tonne Land Rover
Annex B:	Spares and Repair kit

## **SECTION 9: VEHICLE MODIFICATION AND TYRES**

9.1	Categories
9.2	Vehicle Function Modifications
9.3	Crew Function Modifications
9.4	Expedition Function Modifications
Annex A:	External storage for Land Rover windows (pre 1984)
Annex B:	Sun compass mounting
Annex C:	Roll-over-bar

## **SECTION 10: MEDICAL AND SURVIVAL**

10.1	General Philosophy
10.2	Heat and Water-Balanced Related Problems
10.3	Gastro Intestinal Disorders
10.4	Stress
10.5	Routine Medical Problems
10.6	References
Annex A:	Water requirements: Water balance and Survival
Annex B:	Medical Kit

## **SECTION 11: NAVIGATION, MAPS, RESCUE AIDS**

11.1	Constituents
11.2	Application
11.3	Ingredients of Dead Reckoning Navigation

---

11.4	Independent fixing-astro
11.5	Independent fixing-satellite navigation
11.6	Other Aids
11.7	Golden Rule
11.8	Equipment
11.9	Maps and Guides
11.10	Rescue Aids
11.11	Scale of Equipment
Annex A:	Example of Dr Log plotted out to give traverse
Annex B:	Principle of 'Dibbs' Mirror
Annex C:	Equipment List: Navigation kit and maps
Annex D:	Simple heliograph – construction and use
Annex E:	International Ground /Air code

## **Section 12: SCIENTIFIC INSTITUTES OF DESERT STUDIES**

## **Section 13: DESERT BIBLIOGRAPHY**

## Section 1: PLANNING CRITERIA

### 1.1 MAIN CRITERIA

Government Permission  
 Logistics  
 Equipment  
 Personnel  
 Cost  
 Time

### 1.2 GOVERNMENT PERMISSION *Four avenues of initial approach.*

**British Embassy Overseas.** Can steer you round obstacles, indicates where help will be available, put you in touch with appropriate government departments.

**Embassy in UK/Europe of Country Concerned.** Of variable use. Frequently staffed by 'city slickers' unfamiliar with regions you wish to visit and unsympathetic or suspicious of anyone planning to go there. However can be helpful.

**Corresponding Organisation Overseas.** A brother university or research institution overseas in the country concerned can often strengthen and authenticate requests for clearance.

**Foreign Office, Whitehall.** More often than not far more human and sympathetic than popular misconception allows -despite expeditions not being their job. Will frequently direct your enquiries to best sources.

### 1.3 GOLDEN RULES

**Adapt and maintain,** on the expedition, a sensitivity to the country's sovereignty; tact and patience are essential. Though locked into it, foreign officials do not like bureaucracy much more than you do. Recognise the rules they have to apply.

**Allow plenty of time for Government permission.** Letters are not always answered. After your homework, ideally, a visit to the country can work wonders for tricky clearances prior to the actual expedition.

### 1.4 LOGISTICS *Distance from main supply points govern the shape of an expedition.*

*Headings to consider:*

**Fuel,** water, food.

**Vehicle** or other spares, arrangements for fly-in, etc.

**Availability of fuel,** water and food affects choice of vehicles with appropriate payload (and/or number of vehicles/animals in convoy).

**Availability of fly-out facilities** for casevac or, e.g. sending out live samples in natural history collections, exposed film, etc.

**Communications/Rescue.** Always plan to be self-sufficient if possible -multiple vehicles (3 minimum), experienced deputies capable of navigating, etc. A void relying on outside agencies.

**Nearest** comprehensive medical facilities and likely costs.

### 1.5 EQUIPMENT *Capability and scope of an expedition is critically affected by available equipment and its characteristics especially vehicles and equipment below:*

**Vehicle.** Size, cross-country capability (irrelevant unless driver skills also considered - see below), range, and payload. Tools, spares and servicing aids must be studied.

**Scientific Equipment.** Apart from the obvious equipment associated with a scientific programme, photographic, film, navigation equipment and requirements.

**Medical Supplies and Food.**

**1.6 PERSONNEL** *A number of difficult criteria have simultaneously to be satisfied:*

**Skills and Disciplines.** Getting the right skills within a given small group for the planned programmes plus linguists. Pre-expedition training for all team members is essential.

**Availability.** Time away from other commitments over the same period. This includes training and preparatory work prior to the expedition.

**Multi-Role Capability.** Few expeditions can afford prima dona single-discipline specialists. Everyone should be able, when called upon, to cook, change a wheel and, above all, drive delicately.

**Fitness.** Physical fitness essential.

**Compatibility.** Vital. Trust 'gut-feeling' at the selection stage.

### **1.7 COST**

Self evident, but beware the tendency to under-estimate by omitting such items as insurance costs, vehicle carnet indemnities (if required), reserve funds, contingencies (as well as medical insurance) for possible casevac. Especially beware of glib hopes of 'making a film' or 'doing articles'. UK television people are tight-fisted and very reluctant to buy from non-union film makers, besides which production of a film is overall probably more work and cost than the whole expedition.

### **1.8 TIME**

University vacations are at the worst possible time of the year for desert expeditions. Allow time for acclimatisation. Especially allow time for planning, vehicle preparation, team training and getting everything right *before* departure.

## Section 2: EQUIPMENT

### 2.1 OVERALL CONSIDERATIONS AND WEIGHTS

Weight and bulk, in that order, are overriding considerations in choosing equipment. There is always a conflict between what you would like to take and the spare payload available on the vehicle. Never overload your vehicle; respect the manufacturer's figures for gross weight. Lightness is very important -most of your payload is going to be fuel and water. As in all aspects of expedition work, there is no substitute for detailed planning. You will make endless lists, and lists of lists even, but it is the only way to ensure you have the right equipment when you need it.

### 2.2 LIQUID CONTAINERS

**Fuel.** Built-in tanks cannot be off-loaded when a vehicle is badly bogged but do offer compact storage. Metal jerry cans can hardly be bettered for safety and handleability. For large quantities, 45 gallon steel drums are good but a large ex-truck tank's rectilinear shape is lighter and saves space. Dipsticks and accurate gauging daily are essential to give a really accurate daily mpg. Like every thing else, the drums must be lashed down. De-cant from large containers via a siphon tube and jerry can (with calibrated jerry-can dipstick); gallons put in since last full gives mpg.

**Water.** For large Quantities, 45 gallon drums, hard-polythene lined, can sometimes be obtained (ex chemicals storage). Otherwise hard polythene jerry cans, military pattern, are unsurpassed for normal use. If thin "civvy" ones have to be used, lash them down with padded or felt-lined cradles and they will last. Soft, flexible polythene will taint water even in small water bottles; warm and chlorinated, it tastes ghastly.

### 2.3 COOKING EQUIPMENT

Camping Gaz is ideal if you have no gas supply problem. Otherwise Optimus IIIb petrol stoves are light, compact and effective and run off vehicle fuel; so does the Coleman Peak 1 with even more heat output and rather less noise and drama. Both stoves run well on 2-star petrol but coke-up on 4-star. Stainless steel pots can be "washed-up" in sand without producing the black grit aluminium does when scoured; for even heat spread from the petrol stoves, use the ones with thick bases (See notes 'Fuel, Water and Food').

### 2.4 CAMPING GEAR

To save weight don't take a tent; the desert stars are too good to miss anyway. If cold will be a problem use a fibre-pile inner to your sleeping bag, plus a Goretex bivvy-bag. This latter, winter or summer, keeps out warmth-seeking spiders, etc. A mosquito net (one-point suspension type) is essential in some parts of the south. It will often stop enough breeze to double as a tent. Polyethylene foam Karrimat-type sleeping mats weigh about a pound, are warm and comfortable on smooth ground and lighter than the 10 lb safari bed; try them during training first as they may be too thin if you are bony and thin. Mosquito net tucked in round it keeps insects out but do be thorough as they can be very persistent. It feels very cold indeed in the desert overnight, except at the hottest time of the year, especially if other than flat calm -despite temperatures being no lower than 0 to 10°C. Take a really good sleeping bag (full length zip) and a tracksuit to wear inside if you feel the cold.

### 2.5 HELIOGRAPHS/MINIFLARES

Issue to each member of the team, also whistles, and personal rescue/emergency signals. (See notes on Rescue Aids).

### 2.6 PERSONAL KIT

What you wear plus 45 lbs, excluding sleeping bag, is a reasonable allowance for a long expedition. Be firm about weight limitations. Nylon stuff bags for peeled-off clothing, a "small kit" zip bag for regularly used items and cameras, and a "best" bag or suitcase for clean stuff ensures

that what you take is safe and clean. Draught-excluder foam at the suitcase lid edge will help keep out dust. Thin leather gloves keep hands clean and unlace rated in mucky mechanical jobs (also free from sunburn in open vehicles) - washing water will be scarce so it pays to keep clean.

### **2.7 APPEARANCE**

Being on an expedition is not a mandate for being unwashed, unshaven and scruffy - there are cheaper ways of achieving that. Keep fresh clothes to change into before entering towns after long periods out in the desert -especially if you seek police/immigration permission for the next leg. They are not normally impressed by unwashed foreigners.

### **2.8 KEEPING COMFORTABLE**

You can have a refreshing and effective daily wash with a wet Kleenex or Scotty towel. A Braun "Sprint" battery shaver will give over two months shaving on one set of alkaline cells. Disposable paper underwear (from Boots) is useful. Take a spare pair of sun- glasses, lots of lip lube and Nivea, sun oil or aerosol, a wide brimmed hat and a really reliable torch; a Pietzl head-mounted torch is invaluable, leaving both hands free for what you are doing. "Washing up" is often done in sand so take a stainless steel plate and a glazed china mug. List and weigh all your kit well in advance. An example of one man's personal kit taken on a 3 month desert expedition with minimal en-route replenishment is listed at Annex A.

### **2.9 'OFFICE' EQUIPMENT**

It is worth thinking in detail about exactly what you will take. An example of 'Office' kit taken on one expedition is listed (NB lack of vehicle carnet -unnecessary in Algeria) at Annex B.

### **2.10 OTHER EQUIPMENT LISTS**

Lists of other equipment to be considered are as follows:

Vehicle recovery equipment	-see Notes 'Driving and Recovery'
Camera equipment	-see Notes 'Photography'
Vehicle Spares and Tools	-see Notes 'Maintenance and Tools'
Cooking gear and food	-see Notes 'Food, Fuel and Water'
Navigation equipment and Rescue Aids	-see Notes 'Navigation, Maps, Rescue Aids'
Medical Kit	-see Notes 'Medical and Survival'



## Annex A (Equipment Notes)

**PERSONAL KIT**

EXAMPLE USED ON 100 DAY PROJECT WITHOUT SIGNIFICANT REPLENISHMENT - TOTAL WEIGHT 41.5 LBS (Items 2.3 and 4)

**CLOTHES WORN AT START**

Berghaus Igloo windproof jacket in Goretex and Thinsulate. Light golfing jacket (in lieu of pullover). Denim shirt and thin towel neckscarf. Jeans. Woollen socks. Lightweight leather boots. Vest and pants. Thin leather gloves. Cloth hat. Keychain on belt with vehicle cash box key etc.

**SMALL GRIP** - White "Adidas" Bag 16in x 5in x 10in. Wt 13lbs incl. contents.

Sponge bag with Braun battery shaver. pre-shave. toothbrush and paste. nailbrush. Head and Shoulders Shampoo. Nivea. hand towel. Soap and Jeycloth in screw top plastic butter dish (used as washing bowl). Hairbrush. track suit pyjamas. Needle/cotton/etc. Sun oil. tweezers. nail clippers. insect repellent. Murine eyedrops. Puritabs. Nivaquin. plasters. paracetamol tablets. Mac throat tablets. Spare socks. Foot powder. A vomine travel sickness tablets. Two handkerchiefs. Three paper under pants. Alarm clock. Sun-glasses and tinted glass goggles. Torch. Mirror/heliograph. Thermometer (0-50<sup>0</sup>C). Penknife (Swiss Army). Whistle. Length of nylon cord for clothesline etc. Spare gloves. Bootlaces. Small carborundum stone. Mug. spoon. stainless steel plate. Compact camera. Pocket tape recorder for notes. photo data etc. Horse-tail fly whisk.

**FIBRE SUITCASE** - 22in x 13in x 7in. Wt 22lbs incl. contents

Two tubes toothpaste. two packets Mac throat tabs. Three sets spare Duracell shaver batteries. I set U2 type Duracell torch batteries. Two bars of soap. Two tubes shampoo. Three tubes Nivea cream. 6 Lipsalve. Plastic bottle sun oil. Fifteen paper underpants. Two cotton underpants. Two cotton vests. One pair jeans. J pair cotton trousers. One cotton shirt (long sleeves). One shirt (short sleeves). One cotton towelling shirt. One pair KD shorts. One pair KD long trousers. Six handkerchiefs. One spare cloth hat. One medium towel. Three pairs socks. Swimming shorts. Spare sun glasses. Spare gloves. Bottle of liquid detergent (for clothes washing). Towelling scarf. Survival knife. Plastic coat hanger. Spare glass goggles. One box Kleenex tissues. Three spare Jeycloths. French phrase book.

**STUFF BAG** - Nylon. 19in long x 10in diameter, Wt 6.51bs incl. contents.

Second stuff bag (for peeled off clothes. quilted suit (like fibre-pile suit). nylon anorak and trousers. Overalls. Button-on-hood for jacket.

**OTHER PERSONAL KIT**

Sleeping bag. Goretex 'Bivvy Bag'. mosquito net. inflatable pillow. sleeping mat. one litre insulated plastic water bottle.

**BELT-POUCH**

Currently available zipped 'men's handbags' that can also be attached to a waistbelt are a safe way of carrying passports. travellers cheques. UK drivers licence. credit cards. inoculation/vaccination certificates. cash. six spare passport photos. receipts etc. for cameras/watches carried etc. to eliminate risk of theft from kit or hotel rooms.

## Annex B (Equipment Notes)

**OFFICE KIT**

EXAMPLE USED ON SMALL SEVEN-WEEK EXPEDITION TO ALGERIA

**In Samsonite Briefcase 12in x 15in x 4in**

\* See personal kit

\* Passport, vaccination certs

Brochures

6 spare passport pictures

\* Ferry tickets (Channel and Med)

Cash, Travellers cheques

(to vehicle cash box)

Key to vehicle cash box

Expedition file with selected papers

Vehicle Insurance Policies

Vehicle Green card

(overseas insurance)

Vehicle Registration document

'Permission to drive' letter if vehicle not owned by you

\* UK and Intl Driving Licences

List of goods carried (French)

A4 lined paper pad

Clip board

Daily Log book, A4, spiral bound

Sellotape

Scissors

Felt marker pens

Ball point pens, pencils, markers (in zip pencil case)

Books: Desert Animals,

Larger Mammals of Africa

Appropriate scientific monographs, etc.

Sealink and SNCM Ferry

Air mail envelopes

Blank post cards

Elastic bands

Ball of string

Spotstick (glue)

UK cheque book

List of addresses (in file)

Medical insurance policy

Address labels

Stick of chalk (for marking cans)

AA multilingual car parts guide

French dictionaries:

Collins Gem and Harraps

Thermometer (-20oC to +50oC)

Carbon paper

Photo-copies of proposed route

Keys to shovel and ladder rack

Ink and pen

## Section 3: VEHICLES FOR DESERT TERRAIN

### 3.1 MAIN CRITERIA FOR CHOICE

Expected terrain affects how athletic a vehicle you need; logistics and expected additional payload affect the size of vehicle you need.

Criteria:

- Size
- 4 wheel drive (4x4) or 2 wheel drive (4x2)
- Power-to-weight ratio
- Weight distribution
- Ground clearance, associated geometry, suspension
- Petrol or diesel
- Hard top vs soft top
- Tyres
- Modifications
- Trailers

Many expeditions have to do with what is available or what they can afford but an examination of the above criteria helps assess your vehicles in their operational roles. Normally, never take less than two vehicles -three is best since the load from one (broken down) can be transferred and spread without seriously overloading the remainder .

#### 3.1.1 SIZE

In general a large (say 4 ton) truck can support itself and a team over a greater distance and/or longer time than a small vehicle, such as a Land Rover, can. It is a direct function of payload (i.e. fuel or supplies it can carry) and there is no substitute for detailed and accurate calculations of requirements. Power-to-weight ratio drops sharply as size increases so watch this if any bad cross country work is involved. Power-to-weight ratio equals cross-country capability and is usually a direct trade-off for size and carrying capacity.

**3.1.2 4x4 or 4x2.** A robust 4x2 with big wheels and a couple of willing crew to push is surprisingly capable so do not automatically go for the cost, weight and high fuel consumption of a 4x4; a classic frequently seen in Africa in appalling conditions, is the Peugeot 504 pickup. On many -but by no means all -tracks, this will do. There are now a multiplicity of pick-ups on the UK market, some in 4x4 form, but check carefully the payloads, ground clearance, wheel size and wheelbase before making your choice. Consider a 4x2/4x4 mix in a multi-vehicle team. Off-tracks or on known tracks with much soft sand 4x4 is essential; but remember that the wrong tyres, tyre pressure and driving technique can see a bogged 4x4 passed by a 4x2. Whichever you choose never overload it. See also Section 6 (Driving) regarding full-time and part-time 4x4.

#### 3.1.3 POWER-TO-WEIGHT RATIO

Important (with weight distribution and ground clearance) in really demanding off-tracks terrain. 40-50 bhp per ton of Gross Vehicle Weight (GVW) encompasses the best off-road vehicles such as the Range Rover, Land Rover One Ten 3.5 litre, Volvo C303, Rover 1-tonne military etc.. without going to "gas-guzzling" extremes of over-powering that make US vehicles (Blazer et al) completely unsuitable for serious desert work. The old 109in wheelbase 2.25 litre Land Rovers are just about acceptable (but see below), short ones better. Trucks tend to be very low on power/weight so think hard before taking on a combination of demanding logistics (size) and demanding terrain which need an athletic vehicle.

### **3.1.4 WEIGHT DISTRIBUTION**

Ideally this should be 50/50 front/rear and is achieved with the 1 tonne Land Rover (military) or Volvo. LWB Land Rovers and Range Rovers tend to be tail heavy, especially when at max GVW. When loading, keep high density items well ahead of the rear axle and use heavy duty rear springs.

### **3.1.5 GROUND CLEARANCE, ASSOCIATED GEOMETRY, SUSPENSION**

These are all headings contributing to the 1-tonne Land Rover's exceptional performance in the worst cross-country desert conditions. Minimum tail and nose overhang allied to big wheels (good under-axle clearance), good under-belly clearance and a shortish wheelbase give clearance over obstacles. Really supple but well damped suspension (the Range Rover and One Ten Land Rover are the best) contribute to the optimum traction in soft or poor-grip conditions. (See Annex B)

### **3.1.6 PETROL OR DIESEL**

Generally, petrol engines are lighter, more powerful, more thirsty, and cheaper than diesels. Diesels, especially the larger ones, are often longer lasting than petrol engines; they (the large ones) have a wide and flat torque curve making them very suitable for soft sand and slogging. The small, modern, high revving diesel -despite the folk-lore depicting all diesels as sloggers:- often has quite a peaky power curve demanding frequent and rapid use of the gearbox. Diesel vehicles often lack the sprightly panache required for really demanding dune crossing though the latest turbo diesels do well. Diesel fuel (45 p/gal, 1987) is a quarter the price of premium petrol in Algeria.

### **3.1.7 HARD-TOP VS SOFT-TOP**

A soft-top Land Rover can be made reasonably thief-proof, is lighter, less tin-oven-like than a hard-top and lends itself to real open-air driving in the desert - very agreeable. It also fortuitously eliminates the possibility of preposterous roof-racks which should be avoided.

### **3.1.8 TYRES**

Radials are always better than cross-plyes. Mud-type treads are bad for soft sand; Michelin XS tyres are the best desert tyres in the world -radials with a very clever tread pattern. They should be watched on wet tarmac (poor adhesion) and, as with all radials, you must avoid sidewall damage on rocks. They have a range of pressures - about 50% of road pressures on very soft sand, 75% on tracks -enabling amazing performance to be extracted from them on very soft ground. Never run far or fast on soft tyres, always re-inflate to track or road pressures after soft sand has cleared. Always use Michelin tubes (butyl) in Michelin covers. Don't be taken in by the Goodyear Unisteeel 'copy' of the XS available in 12.00x20 (Bedford) size. (Michelin at Stoke-on-Trent or Harrow will supply tyre load/pressure data).

### **3.1.9 MODIFICATIONS**

Recommended are: (but see notes on Vehicles Modifications and Tyres).

Oil temperature gauge

'Swirl' -type air intake cover

Electronic ignition (Lumenition works well)

Gaiters on prop shafts and steering joints

Battery master switch

Bolted-in lockable cash/valuable box under bonnet

Ventilated seat backs (basket/wire)

Extra fresh air vents

Double roof on hard top Land Rover

Tie-down points to secure load to eliminate rattles

Avoid roof racks.

**3.1.10 TRAILERS**

Not as bad as often thought though an obvious problem reversing out of boggings. However, a given load may be spread over 6 instead of 4 wheels and so long as 2-3 people are available to manhandle, and the trailer is loaded to only .5 to .75 maximum load and fitted with XS tyres at the right pressure, it can be invaluable.

Annex A (Vehicle Notes)

**GROUND CLEARANCE AND ASSOCIATED GEOMETRY**

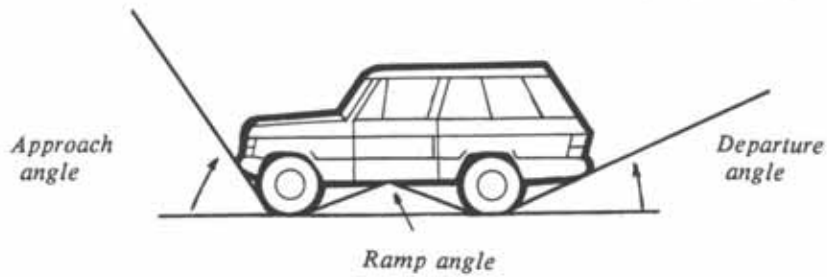

*On a given slope . . .*

*. . . a very good approach angle . . . .*

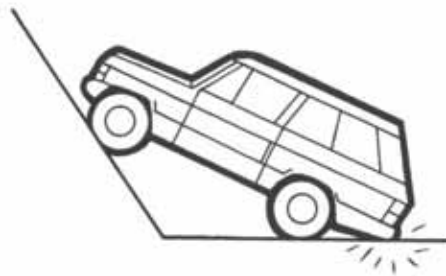

*. . . is meaningless without a departure angle of the same order.*



*A good ramp angle is important and results from a combination of large wheels and a shortish wheelbase. Thus on similar wheels the Range Rover (100in WB) will have a better ramp angle than a LWB Land Rover (109in WB)*

## Annex B (Vehicle Notes)

**LOAD DISTRIBUTION AND LASHING**

*Example of loading and lashing used on long distance expedition. Aim is to achieve 50/50 front/rear load distribution if possible; also to stow high density loads (such as water drums) ahead of the rear axle to help achieve scientific instruments are also stowed as close as possible to the mid-wheelbase position.*

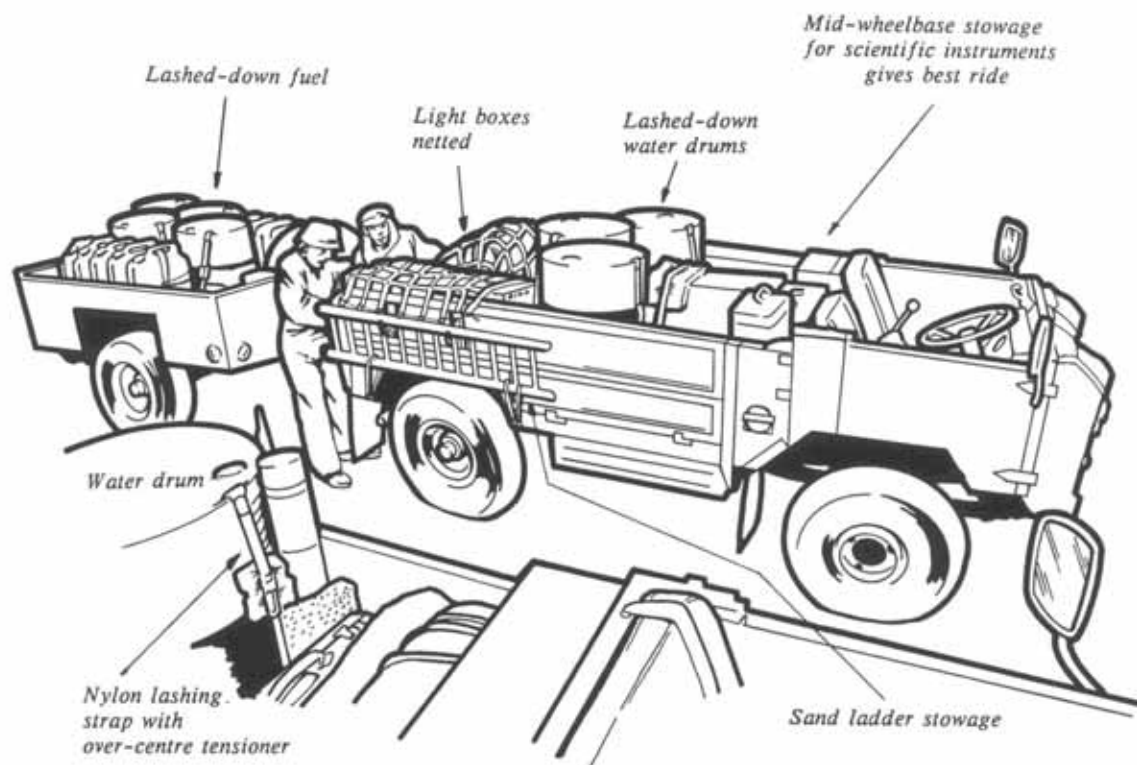

## Section 4: FUEL, WATER AND FOOD

### 4.1 FUEL

**4.1.1 How much to carry.** It is as vital to carry sufficient fuel and sensible reserves in the desert as it is not to overload the vehicle. Fuelling points are invariably widely spaced; the distance between them -as shown in the notes on Vehicles for Desert Terrain - is a major criterion in selection of vehicle, total payload and payload left over for crew and other supplies. If D is the distance between fuelling points:

Total gallons required =  $D + 25\% + 100$  miles all divided by the expected mpg.

(i.e. a reserve of 25% plus 100 miles to cover diversions and difficult going).

**4.1.2 Distances.** Away from tracks (e.g. an expedition reaches a base supply town and then branches out to a study region across country) D will be a distance measured off a map. Factor it according to terrain; on a big map (1:1m say) actual distance will be about 1.2 times measured distance, given reasonable going such as gravel and some stony regions. Savannah, slow going with much zig-zagging between grass tussocks will 1.3; sand dunes 1.5 to 2; smooth sand/gravel plain 1.1.

**4.1.3 MPG.** Some actual Mpg's encountered are:

#### *Tracks and Tarmac*

Land Rover, 1-tonne military (V8)	14-18 mpg
Land Rover, LWB, 6 cyl, UK-Gulf	15-18 mpg
Land Rover, 2.51 Turbo Diesel	23-27 mpg
Range Rover, UK-France touring	14-21 mpg
Range Rover, + 12 cwt trailer	9-19 mpg
Range Rover, 7.50 x 16 Michelin XS tyres	
bad track:	12-15 mpg
fair track, tarmac:	15-20 mpg

#### *Off Tracks, Open Desert (Sand, Rock, Some Dunes)*

Land Rover, 1-tonne military (V8)	7-14 mpg
Land Rover, L WB, 6 cyl, Libya	11-14 mpg
Land Rover, LWB, 4 cyl, Mauritania	10-12 mpg
Land Rover, 2.51 Turbo Diesel	22-25 mpg
Range Rover	10-15 mpg
Bedford RL 4-ton truck	2-5 mpg

**4.1.4 Fuel Accounting.** It is essential to do a nightly calculation of MPG and check on fuel remaining in tanks and cans. Know the exact number of gallons to top up each night and divide it into distance covered. Use a jerry can dipstick calibrated against a petrol station pump in the UK to establish the fuel put in.

### 4.2 WATER

**4.2.1 How Much to Carry?** The human body is a machine relying on the simple - unchangeable - laws of physics to maintain water-balance and ultimately, to maintain the performance of its thermoregulatory apparatus. There is thus no such thing as a tough person being able to do with less water than a cissy. Both respond to the same laws, like it or not. Both will only perform well if they have enough water each day. A simple guide to 'enough' being the frequency and colour of urination. Infrequent urination, passing dark urine (that sometimes stings), often accompanied by headaches and extreme fatigue are indications of insufficient water intake. Dizziness, nausea, cessation of sweating and a rise in body temperature indicate things have gone too far and the



person is in danger -see notes on Medical and Survival (also guide to survival on given amounts of water).

Personal experience over a number of expeditions show water required at low physical work loads:

1.5-2 galls/head/day with night/day min/max 5 to 35°C

2.5 to 4 galls " " " " 25 to 45°C

**4.2.2 For How Many Days?** No hard and fast rules here but a minimum of three extra days' worth is a prudent reserve to cover. say. time-consuming breakdown repair work. Thus a journey involving 6 days' travel should take 9 days' water. Radio, rescue facilities, work load at regions of scientific study, replenishment potential must all be considered.

**4.2.3 Purification.** Halazone (Steratabs. Puritabs etc) are effective. If in doubt purify, though most communal tap supplies in Algeria appear to be satisfactory to use as they are.

**4.2.4 Survival Consumption Rates:** See notes 'Medical and Survival'.

### 4.3 FOOD

**4.3.1 Dehydrated or Tinned.** Weight being an ever present problem. the lightness of dehydrated foods has its attractions. In general, if water is readily available en route the weight saving can be considerable and provisioning for a whole expedition is feasible using dehydrated foods. However, over long waterless regions dehydrated food plus the water with which to reconstitute it weighs as much as fully constituted tinned rations - and is probably less pleasant to eat as well as requiring more cooking fuel.

**4.3.2 Eating Patterns.** Long hour, hot days and night temperatures, that subjectively, feel very cold characterise the desert expedition environment. Contrary to what might initially be expected there is a requirement for substantial and filling meals -though not at the midday period. Many expeditions find it both desirable and convenient to use an eating pattern something like that listed below.

Breakfast - Cereal or porridge (with hot milk) or  
sausage and beans type.

Bread/biscuits with margarine/ jam

Tea/coffee

Lunch snack – Bread/biscuits with tinned savouries/ jam.

Tinned fruit

Tea/coffee

Evening halt – Tea followed an hour later by:

Meat and veg main course

Dessert

Biscuits if required

### Tea/coffee

**4.3.3 Diet.** No special changes of diet are called for or wanted. High protein, low residue foods such as tinned stews, especially when combined with the possibility of inadequate fluid intake associated with high ambient temperatures can lead to constipation so take care to include plenty of tinned fruits, and other palatable roughage such as All Bran breakfast cereal. Naturally bread and fresh fruit and vegetables should be bought locally where possible en route. Baking your own bread is feasible -a one cubic foot metal box oven (covered with cooking foil externally to cut heat loss) used over a petrol stove is effective; breadmix, dried yeast and water are the ingredients. As well as common sense considerations of what is nourishing and palatable, remember ease and speed of separation are important as well as elimination of water-wasteful operations such as rinsing rice or elaborate washing-up, (see below). Opal Fruits or similar sweets for sucking en-route recommended.

**4.3.4 Cooking Stoves.** As mentioned in the notes on Equipment, Camping Gaz is an ideal cooking medium -clean, safe and controllable -but cylinders are heavy and there can re-supply problems. It is however, widely available in Algeria and expeditions based near large settlements may find it satisfactory. Petrol stoves are very light, extremely efficient, and run off vehicle fuel (2 star) so are probably best for most expeditions. Kerosene stoves are not recommended since a can of special fuel is required -again extra weight.

**4.3.5 Utensils.** Paradoxically, it is worth investing weight in stainless steel, heavy-based cooking pots -they spread heat without burning the food and are easier to wash up with minimal water (note there is no extra water allocated for cooking. All, including washing-up and personal washing, comes out of the per-head daily allowance). Heat food in the tin (in boiling water) where possible to save cleaning; for this a thin alloy saucepan or pot can be used.

**4.3.6 Hygiene.** Hygiene must be uncompromisingly high. It is worth reading that sentence again. Always camp away from population centres if possible. Be meticulous about burning and burying rubbish -or take it away with you to a place where you can bury burn. Paper kitchen towels aid hygiene, are invaluable, multi-purpose and light; take plenty. Insulex mugs (double-walled plastic), though hard to keep clean, are highly commended for keeping hot drinks hot. See Annex for some specifics on food and cooking gear.

**Annex (Notes on Food)****COOKING GEAR AND FOOD**

Below is a list of equipment and food taken on a 6-week one-man expedition in desert regions using bought-out oranges and bread when available. It may serve as a guide to be modified according to numbers and special requirements.

**Cooking gear and storage:** In insulated 'Picnic Box' 12 x 14 x 7 1/2

Olfstrom stainless saucepan (thick alloy base)  
 Stainless plate and lid  
 Knife, fork, spoon, teaspoon  
 Alloy kettle  
 2 dishcloths  
 Alloy small saucepan & lid (for heating tins)  
 Plastic stirring spoon  
 Insulex mug  
 2 jeycloths  
 China mug  
 Tin opener  
 'Guest' mug  
 Nylon Pan Scrubber  
 250ml plastic container  
 Plastic bag with: Matches, lighter, handle for small saucepan, sterotabs, key for sardine cans, compo tin opener, vitamin tabs, spare jets for Optimus stove.

Not boxed: Coleman Peak I petrol stove,  
 Camping Gaz Bluet 200 standby stove  
 Water syphon pump (jerry can to kettle)  
 Petrol syphon pump (jerry can to stove)

**Food:** 2 boxes each containing 10 24hr GS military 'compo' rations and Food extras (approx 7 days and supplement to above):

72 teabags  
 2 lbs sugar  
 3 pkt Ryvita  
 1 tub Flora margarine  
 1 lb marmalade  
 1 tin Smash dehydrated potato  
 1 jar marmite  
 10 pkts Opal Fruits  
 4 pkts dried soup  
 4 pkts Bachelors inst custard  
 8 kts Rise & Shine (Kellogs)  
 1 lb Salt  
 12 small tins of fruit  
 1 large Marvel milk powder  
 7 small tins meats (corned beef, steak/kidney, sausage/beans)  
 7 small tin tomatoes  
 small tin curry powder  
 1 small Fairy Liquid

1 roll narrow aluminium foil  
1 pkt All Bran 680 grm  
Pepper  
4 dehydrated Beef Risotto (Vesta)  
1 pkt Alpen  
3 rolls Kleenex Kitchen towels  
1 bot Dynamo liquid deterg  
1 box Kleenex tissue  
3 toilet rolls

**End -of expedition unused rations:**

12 (out of 20) compo rations  
3/4 bottle Fairy Liquid  
3 beef risotto  
1 helping All Bran  
1 tin fruit  
1 roll Kleenex Kitchen towel  
1 sausage/beans  
2 1/4 rolls toilet paper  
1/10th tin Marvel  
About 1 doz small pkt sugar ,  
3 spoons sugar (!), milk etc from Compo rations  
2 pkts Ryvita  
All the pkts dried soup.

**Would have liked more:**

Flora  
Marmalade  
Cereal  
Smash  
Marmite  
Bachelors Instant Custard

## Section 5: PERSONNEL AND TRAINING

### 5.1 AIM

The aim of all personnel selection and training prior to an expedition is to make that expedition effective. That is not so self-evident a statement as it may at first appear since the effectiveness and team effort from an expedition are influenced by many subjective and intangible factors outside the apparently cut-and-dried business of recruiting say, one mechanic, two cooks and four geologists.

Inextricably tied in with the Quantifiable such as age, paper Qualifications and number of previous expeditions a candidate has done are a person's adaptability, cheerfulness, practicality, sensitivity, compatibility with others and motivation for the project. All these are Qualities that affect the achievement of an expedition to a great degree since they have a critical effect upon its morale and team spirit.

The leader must assume a god-like role in selecting his team and enormous responsibility lies with him. But if the writer had to crystalise the lessons of the past 20 years, two main points come out:

**Motivation** -keenness to be on the expedition -is the most important single factor in the selection of the candidate.

**Always** trust your own judgement and 'gut-feeling' about a candidate and never take anyone you are unhappy about.

The following paragraphs report on the actual personnel selection and training for an 8- man, 100day expedition in the Sahara and its subsequent effectiveness.

### 5.2 REPORT: PERSONNEL SELECTION

The ultimate aim in personnel selection and training was the same as the philosophy of the whole expedition -infallibility. The problem faced was very akin to that of flying an aircraft: a human being on its own at 30,000ft is in a potentially very dangerous position but with adequate training and teamwork in the right machine the situation can be made safe. Likewise in a desert expedition there is no room for error; the consequences of error or failure are so serious as to be unacceptable -hence infallibility must be the aim. Most failed expeditions or enterprises fail through human error -either directly through insufficient training or indirectly through poor planning, i.e. failure to appreciate dangerous contingencies or potential natural hazards.

In this expedition the keynote was proper operation of the vehicles up to, but not beyond, their limits. These limitations vary according to terrain, load, speed etc, and a prime requirement in all candidates was 'mechanical sympathy'. From this, with training, would stem good driving and, with perception and sensitivity, driving as nearly infallible as it was possible to get. On top of 'mechanical sympathy' had to be motivation -the next most important Quality. Sheer keenness on the project would breed resilience and tenacity, lend motivation to train, to perfect skills, to overcome obstacles and, in an environment of similar motivation from others, go far along the road to establish compatibility with the team.

A great deal of individual expertise was required in addition to the Qualities common to all team members mentioned above. The overall requirement on the personnel side was summed up in the original call for volunteers: "Expedition conditions are likely to be demanding. Extremes of temperature (hot and cold), long periods of travel over rough, bleak, uninhabited terrain, and repeated physical activity will be the background against which very high standards of human reliability will be essential, manifested in care of vehicles and equipment, the highest standards of cross-country driving and general attention to detail in the discharge of often routine tasks". If the

expedition is to achieve its aims and the necessary harmony within the team maintained, fitness, stamina, sense of humour and above all the strongest motivation towards this kind of project will be essential in all team members. The optimum amalgam of the following Qualifications will be required within the team and many may apply to each team member:

- Previous expedition, hot climate or desert experience
- Cross country driving experience on Land Rover or Bedford
- Mechanical aptitude or sympathy
- Radio operator/fitter experience (RF)
- Use of theodolite for astro fixing
- Geological Qualifications or knowledge
- Medical Qualifications
- Knowledge of French or Arabic

Some skills were more difficult to find than others and the choice was sometimes limited. Nevertheless the criteria mentioned, reinforced by hindsight experience on the expedition, remain valid and precisely to the point. 155 volunteers were forthcoming initially. The requirements above and the additional problem of location and availability for training whittled this three months later to about 40 for interview. To make interview selection as objective and Quantitative as possible, candidates were marked in accordance with Annex A and a 'short list' of about 20 went on to cross country driving tests at Aldershot. This was very time consuming but was aimed at choice not so much according to overall competence at that time but according to mechanical sensitivity and training potential. A group of about 12 then went on to regular driver training from March/April until October/November. This was combined with camping-out at the rough-terrain training areas near Aldershot and Bordon in Rants and was used as a familiarisation on expedition procedures for the future.

Selection of the team from the 12 then depended upon the results of the training set out below and upon the degree to which the criteria in para 7 could be met by various combinations of personnel from within the group. The inevitable Service commitments such as postings, availability of replacements etc., had a further effect on the selection. Selection of prime team and reserves from the group of 12 was made late in October. Two of the three reserves subsequently withdrew.

### **5.3 TRAINING**

**5.3.1 Driver Training.** Driver training was allocated highest priority in the training programme since cross-country driving is not widely practised and is very rarely taught in such a survival orientated context. The training notes used (Annex D to Notes on Driving) angles towards proficiency on the 109in (.75 ton) long wheelbase 4 cylinder Land Rover (Series II) with synchromesh on 3rd gear only. This vehicle is a good training vehicle since it has an unforgiving ride, relatively poor axle articulation and limited underbelly ground clearance and steering lock. Accent was on meticulously careful driving, on-foot recce before an obstacle and marshalling through hazards where clearance was in doubt or where tyre damage might result. 'Tyre consciousness' was also emphasised -different pressures for road, track and soft going, different pressures for rock and sand, the effect of weight on recommended pressures and the vulnerability of radial tyre sidewalls to rock damage. The team also practised removal of tyres without damage. In the driving sessions deliberately 'impossible' traverses were attempted so that precise marshalling, 'landscaping' (removing obstacles by shovelling), and single and tandem towed recovery could be practised. Trailer towing cross country, reversing and de-coupling for recovery as well as extreme climbs and descents were all practised in the roles of the driver, marshaller, and supervisor. All vehicles were driven where possible without side windows or canvas roofs (as on the expedition) in order that optimum visibility could be obtained. Each team member had a 2-4 hour familiarisation/assessment drive during the personnel selection stage. Week-end training, of which each team member had about 6 sessions, began in June and was invariably combined with at

least one night camping out without tents. Naturally some feel for compatibility within the team was possible during the training.

**5.3.2 Servicing.** In addition to basic knowledge taken into consideration during selection, a familiarisation visit to Rover Splihull and a Servicing School session of four days at British Leyland Allesley was arranged.

**5.3.3 Astro Navigation.** A two week course at the School of Military Survey on desert navigation and astro fixing using a theodolite was arranged for four of the group.

**5.3.4 Language Training.** The leader took a nine-week refresher course in French prior to leaving on a diplomatic visit to the expedition area in June.

**5.3.5 Cinematography.** Three members of the group attended a week's course on cinematography at the Fleet Photographic School at HMS Excellent. The actual cine cameras to be used on the expedition were available to practise on; this was considered essential to achieve the requisite familiarity.

**5.3.6 Parascending.** Weather continually forced cancellation of projected training sessions but one was achieved. There were experienced parachutists in the team.

**5.3.7 Medical Training.** No doctor was available to include in the team but there was in any case a need to have all members familiar with the most common contingencies. The RAF Institute of Health and Medical Training at Halton arranged a two day briefing for the team and included practice at the administration of intra-venous saline drips in cases of heat exhaustion and severe dehydration. Emphasis was laid on water purification procedures, treatment of gastro-enteritis, precautions against endemic diseases, inoculations and the use of various drugs.

**5.3.8 Fitness Training.** This had for the most part to be left to the individuals but the limitations of both the concept and method of administration were appreciated. It was impossible to say with certainty that a given type of training would produce a given result on the expedition since, as mentioned above, motivation was far more important. It could be said, however, that for a given motivation a better stamina and tenacity would come from a fit man than an unfit man. The type of fitness and training required was open to considerable discussion but Aerobic training (1.5 mile run) offered an easily quantifiable criterion to work against. Whilst this was good for CVR development and tone, circuit training was used as a more general fittening process. All this training, done in the candidates own time and as a result of his own willpower, is also a useful indication of his general motivation and as such is an aid to the final selection process. The training was generally unpopular and it was necessary to run a test weekend to establish standards; training was also continued again on an individual, voluntary, and not very effective basis during the pre-departure phase. Hindsight dictates that stricter supervision and go/no-go tests (with due allowance for the widely different types of fitness for different people) at regular intervals would have been more advisable. However, eventual standards by the Aerobic training criteria were good or excellent.

**5.3.9 Miscellaneous Training.** Other training carried out came under less formal categories but covered familiarisation with the radio-equipment, camping gear, gravimeter, vehicle servicing and tuning gear and preparation of reptile preservation equipment.

## **5.4 EN ROUTE ROUTINE**

Enroute routine was important to establish, particularly in relation to job allocation so that all the tasks were adequately covered and evenly spread amongst the team. In general, camp was set up away from centres of population or villages since this presented least hazard to health or from

potential thieves. Lightness being of prime importance since most of the vehicle payload was allocated fuel and water, full sized tents were discouraged though lightweight units were produced and used by some members.

The team rose just before dawn and aimed to be on the move about 60- 75 minutes after getting up. Breakfast was eaten, tyre pressure and vehicle coolant water checked; sun compass settings were checked (Local Apparent Time calculation and latitude setting as well as alignment compared with a magnetic compass). Set convoy order was maintained and was as follows:

**Lead vehicle.** Leader and navigator/co-driver.

Prime Navigation Gear, cine sound and still photographic gear. Green expedition flag on pole to aid identification by following vehicles.

**Second vehicle with trailer.** Geophysicist and deputy leader/French interpreter.

Gravimeter and aneroids, medical kit, spares and tools.

**Third vehicle with trailer.** Radio operator and Arabic translator. Radio gear .

**Fourth vehicle without trailer.** Cook, 3rd mechanic. All cooking gear, water pump and filter. Red ensign on pole to aid identification by lead vehicle.

Route information and DR log was kept by the lead vehicle co-driver (see Annex A, Notes on Navigation) and stops were made normally every 20km for gravity, aneroid and temperature readings. Water bottles could be refilled during gravity stops. Stops were also necessary for filming and where possible these coincided with gravity stops though inevitably they could not always be predicted either in location, time or time taken. The timing of the radio-call at 12.00 GMT was made the basis of the lunch halt. Normally a stop 10 minutes before 12.00 GMT was enough time to get the aerial erected and whilst this and the radio call were going on the lunch snack and tea was being prepared. It was seldom possible to achieve the combined lunch stop and radio call in less than one hour and frequently where there was a lot of signals traffic it took longer. Water bottles were refilled at lunch time and sometimes cine camera film changing was carried out.

Afternoon routine was similar except that drivers and co-drivers exchanged seats at lunch time. This gave each man 24 hours driving broken by a night's rest. The expedition halted about 1.5 hours before sunset in order that the majority of the evening workload could be achieved during daylight. In particular any vehicle maintenance or repairs could be done before dark. The camp was set up in an open ended square formation, the two trailers forming the up-wind side, the lead vehicle the western side and the cook vehicle the eastern side with cooking being done a safe distance away from petrol containers the vehicles carried. Each vehicle had a 12v fluorescent light which could be clipped where required for evening work. Particular tasks to be done at the evening camp halt were:

- Vehicle daily inspections
- Refuelling and calculation of mpg. Refilling cans.
- Prepare initial brew of tea and main meal later
- Begin reduction of gravity data.
- Calculate DR position and gravity station positions.
- Set up Theodolite for subsequent after dark astro shots.
- Remedy any vehicle unservicability.
- Refill (and if necessary purify) water jerry cans.
- Mark and preserve any lizard collections.
- Mark and pack any rock collections
- Catalogue still film shots



- Catalogue cine film sequences
- Clean and reload still and cine cameras
- Monitor and log any cine sound recorded
- Write up daily log
- Enter any expenditure in accounts
- Re-stock rations from main boxes
- Layout bedding and personal kit, wash and shave (.5 pint)

Normally one or two members of the team were working until 10 or 12 pm every evening. Guards were not routinely mounted but when this was done (in populous areas) a roster of 1 hour per man was adhered to since this way there was not too much disruption of sleep. The cook, who always had early duty was given the last position on the guard roster 5 to 6 am.

Staying in hotels and rest houses when it was necessary was found to be more trouble than it was worth -albeit the showering and clothes washing facilities were welcome. It was invariably after such stays in towns that gastro enteritis infections struck the team; the desert and open country was always cleaner and more healthy.

A small expedition such as this demanding a multi-skilled team all imbued with a common feeling for mechanical things and a love of the desert is probably one of the most difficult selection problems it is possible to find. The most important single selection criterion is keenness since it leads to the drive to attain the high standards required, provides at the same time the enjoyment of the environment that lessens stress which in turn produces the team spirit that overcomes unforeseen difficulties.

Together with thorough planning, the training -especially the driver training -was one of the major factors leading to the success of the expedition. Care in the operation of the vehicles whilst stationary or on the move was the theme of the training and thoroughness and attention to detail the keynote.

## Annex A (Personnel and Training Notes)

## INTERVIEW MARKING SCHEDULE

Candidate's name:																				
Attribute	Max *																			
<b>Personal Qualities</b>																				
Motivation	9																			
Rapport	9																			
Intell/sensit	9																			
Practicality	9																			
Present fitness	7																			
<b>Experience</b>																				
Hot climates	3																			
Outdoor Life	5																			
Desert expeds	5																			
Land Roving	5																			
Survival etc	4																			
<b>Specialisation</b>																				
Radio op	7																			
Nav/survey	7																			
Doctor	6																			
Geologist	6																			
Rock climber	4																			
Photographer	5																			
Mechanic	6																			
French/Arabic	6/5																			

\*These maxima introduced appropriate weighting according to the importance of the attribute

## Section 6: DRIVING AND RECOVERY

### 6.1 OVERALL PHILOSOPHY

Restrained, sympathetic and alert driving is probably the most important characteristic to inculcate into any expedition team going on a long and arduous expedition, especially if it is likely to cover many miles on tracks or across open country. We are unhelpfully surrounded by four-wheel-drive magazines that feature brutish driving, airborne vehicles, flying dust, chrome spotlights and dummy exhaust pipes as though these were the ingredients of professionalism. In a sense, since it is normal for the media to dramatise trivia and lionise the extrovert, we have at least an inverted guide on what to avoid. The vehicle is the very core of the expedition; certainly considerable cost, if not life itself, will be at stake if it is not looked after well and driven considerately. Whilst the best 4x4's do convey a feeling of being unstoppable, anything will break given enough abuse, so the urge to prove one's manhood (or liberated status) by driving with excessive panache must be resisted.

But points of technique are important as well as just care, since there will be times, especially in soft conditions, where all the vehicle's power output will have to be used.

### 6.2 GEARBOX AND TRANSMISSION

**6.2.1 Main Gearbox.** Know your gearbox and, if it is manual, especially know which gears have synchromesh; those that do not you will have to double-de-clutch into, changing up or down. Practice this until a smooth silent change can be made into all gears - including first -even over rough going. Avoid slipping the clutch. Keep your foot off it unless starting, stopping or changing gear. This may require will-power but it will save the life of your clutch.

**6.2.2 Transfer Box (Range Change).** Most four-wheel-drive vehicles (4x4s) have a low ratio selector (sometimes called a range change) that will gear the vehicle down by a factor of about 2:1 whatever gear is selected in the main gearbox; it is termed a transfer box because as well as dropping the overall gear ratio, in many cases it transfers the drive not only to the rear propeller shaft but also to the front propeller shaft and hence effects a change from two wheel drive (4x2) to four-wheel drive (4x4) when appropriate selections are made -the Red knob moved aft in the series 1, 2 or 3 Land Rover. Vehicles with a transfer box of this kind will usually have a means of selecting 4x4 in high ratio as well (Yellow knob pushed down in the Land Rover); the control can be either separate or an intermediate position on the range change lever. Follow the manufacturer's recommendations regarding when range changes can be made; in many older vehicles this must be done while stationary. Whatever the technique recommended, the over-riding consideration is to make these changes without clunking, crashing gears or shock loading the transmission. This can often be accomplished with a straight double-de-clutch using the range change lever. Sometimes, though, the main gearbox ratio must be changed at the same time, as in the Land Rover. Ways of accomplishing this are indicated at Annex D lessons 5 and 6.

**6.2.3 'Full-Time' and 'Part-Time' 4x4.** It is essential to be aware of the differences between 'part-time' 4x4 -i.e. a two-wheel-drive vehicle in which you can select four wheel- drive when required -and 'full-time' 4x4 in which the vehicle is in four-wheel-drive all the time. As indicated below, even this 'full-time' 4x4 can be with or without locking of the centre differential.

*'Part-Time' 4x4.* Lets take the case of a Series 2 or 3 Land Rover. Driven on normal roads, the vehicle is in high ratio (red knob forward) and two-wheel drive (yellow knob up ). If you need 4x4 in high range just press down the yellow knob; this can be done on the move but depress the clutch as you do it. Selecting low range by pulling the red knob aft selects 4x4 as well as lower ratios. Stop before you do this (but see Annex). When either of these selections is made, the front and rear propeller shafts are geared, invariably, together. As well as improving traction this also means that the small differences in revolutions-per-mile between the front and rear wheels (due to steering etc)

cannot take place so, on hard roads, the transmission system is placed under higher than normal strain and rotational tyre scrub will take place. If you drive a Land Rover in 4x4 on hard grippy surfaces and try a full-lock turn you will feel the stiffness in the steering and the odd feedback from the front wheels. On loose surfaces the wheels can slip rotationally and so accommodate this difference in axle speeds. Note that this basic problem is caused by the front and rear prop shafts being geared, invariably, together.

*'Full-Time' 4x4.* In a vehicle where drive is always to all four wheels, such as the Range Rover or the Ninety and One- Ten Land Rover, this transmission wind-up and tyre scrub is eliminated by putting a differential gear between front and rear prop shaft. Normally this effects a variable gearing between the front and rear axles, that can accommodate the difference in rotational speeds; to quote an extreme case, if the rear axle was locked so that it could not rotate then all the drive from the engine would be fed, through the differential, to the front axle and the front wheels would rotate twice as fast. Thus a 'full-time' 4x4 with this centre differential can be driven on firm surfaces without detriment to the wear of tyres or transmission and without odd steering characteristics. But it is still possible for this elegant arrangement to be misused by an ignorant or forgetful driver. Provision is made to lock this centre differential to cope with extreme off-road low-traction conditions such as deep mud or sand. The front and rear prop shafts are then geared directly and invariably together. Thus a driver who engages this diff-lock in soft going and forgets to disengage it on tarmac will be causing excessive tyre wear and stress on the Transmission shafts.

**6.2.4 When to use 4x4.** Having said all this -and it will be clear that the main use of selectable or 'part-time' 4x4 is in poor traction, soft sand, conditions -there are still other times when 4x4 should be selected. These are when travelling corrugated (see Corrugations) or exceptionally rough tracks. In these conditions the shock load reversals on half-shafts are extreme as the wheel jumps from one bump to another; use of four- wheel-drive spreads these loads over four half-shafts rather than two thus halving the fatigue loads. Using a 'full-time' 4x4 vehicle in these conditions it would not be necessary or desirable to lock the centre differential; however, during use of such a vehicle in very soft sand, it will often be beneficial to lock the centre differential to prevent a single spinning wheel from robbing traction from the other three. With the diff-lock engaged at least it can only rob traction from the other wheel on its own axle (unless, as in the Mercedes Geländewagen there are cross-axle diff-locks as well.)

### **6.3 SUSPENSION AFFECTS TRACTION**

A more common problem associated with transmission and which is probably responsible for more than half of all 'failed traction' situations -bogging in soft-going included -is the 'diagonal suspension' case. Imagine a driver's eye view approaching a shallow V- shaped ditch going diagonally, 300 left of dead ahead direction, from distant left to foreground right. In crossing it the vehicle will reach a condition where the front right wheel is on the far side of the ditch, the rear left is on the near side of the ditch (the diagonal suspension situation) and the other two remaining wheels are hanging down into the bottom of the V. When the ditch is deeper than the extent of the wheel movement allowed by the vehicle's springs, these wheels (left front and right rear) will spin in thin air and, owing to the axle differential, all the power will go to them and traction will be lost. Different variations of this classic basic situation will manifest themselves in a hundred ways - scrambling up bumpy slopes, crossing ruts, on rough ground or in soft going. Almost invariably it will be 'diagonal' wheel-spin that stops a 4x4 in severe going. A lockable or limited slip differential in the axle(s) is the answer but if this is not available it helps to be on the look-out for, and quickly recognise, this condition and stop before wheelspin makes things worse by scooping sand or earth beneath the afflicted wheels. The torque of the propeller shaft power tends to tilt front and rear axles in opposite directions relative to the chassis in a soft-sand-and-wheelspin bogging: *avoid wheelspin, admit defeat early, reverse out.*

By quitting early, excessive under-wheel scooping is avoided and reversing out conveniently tends to tilt the axles in the reverse direction thus enhancing your traction for getting out backwards anyway. As in line one, it comes down to restrained, sympathetic and alert driving.

#### **6.4 TRANSMISSION BRAKES**

A final point on transmission: where a transmission brake is fitted (a brake drum on the prop shaft behind the gearbox as on the Land Rover, Range Rover or Bedford MK); it should *never* be used except when the vehicle has been brought to rest with the wheel brakes and is *stationary*. If used on the move it can cause half-shaft failure and severe stress in the transmission. Think of it as a parking brake only.

#### **6.5 SLIPPERY CONDITIONS, POOR TRACTION, SLOPES**

Jumping off a meringue or piecrust is the best analogy to poor traction conditions - mud, sand, bog, snow or slippery hills. Low surface strength and low shear strength are common to all and the demands of both must be reduced. Fitting big, high flotation tyres and lowering tyre pressures reduces vertical load per square inch and going from two to four-wheel-drive halves the shear strength required of a given piece of ground. (See diagram at lesson 2, Annex D). Both these remedies must be allied to smooth driving, use of the highest reasonable gear and very gentle use of the accelerator. This implies, too, getting the required gear and speed before the obstacle -a gear change at the wrong time can sometimes cause a bogging or a failed ascent. The driving technique is especially important on slippery inclines where too Iowa gear (say first, low range ) will make wheelspin all too easy to induce; a climb can more reliably be made by using second gear and a gentle right foot.

Avoidance of wheel skidding (the opposite of wheel spinning but still a major difference between tyre speed and ground speed) must be borne in mind also when descending steep slopes -the same gear must be used to go down as would have been appropriate for going up; most usually second gear low range, occasionally even third, never first. (First gear low range is best used for slow, controlled traversing of really rough savage going such as rock, boulders or 'doorsteps'; there is generally too much torque for poor traction conditions and wheel spin results). Too Iowa gear in a descent enhances the possibility of a sliding glissade where the engine cannot 'catch-up' with the rate at which the vehicle is sliding down the slope.

#### **6.6 OBSTACLES, RECCE AND MARSHALLING**

If in doubt, recce on foot -hills, gullies, bumps in the track, anywhere where you have any doubts that the vehicle can clearly traverse the obstacle ahead. On the umpteenth hot, sticky day of a rough expedition in the tropics the temptation to press on and hope for the best will be high, but the cost of getting it wrong -just once -will be higher . The passenger should be used as a marshaller where clearances (especially over rocks under the vehicle) are tight. There is a tendency for everyone to shout at once in these situations but the driver should take his directions from just one marshaller (about 40ft ahead and facing the driver with a good view of all four wheels and the under-belly clearance). These directions should be visual rather than by shouting and mishearing over engine noise. An agreed system of marshalling signals should be practised during pre-expedition driver training; go-right, go-left, advance, stop and reverse are all that is necessary. The driver must obey and trust the marshaller completely and watch him, not the track, when being guided.

In difficult going of the kind where marshalling is needed, shovels should be regarded as an emergency low gear and must regularly be used to safeguard the vehicle; if the obstacle is likely to hazard the vehicle then 'landscaping' can remove the offending rock or bump or provide a feasible path for a wheel. Do not skimp the digging; invest another five minutes in shovelling and be sure of getting out first try.

## 6.7 FLOTATION ON SAND OR SALT FLAT

All sand offers better flotation and traction when cool, dewy or damp; a bad bogging in the heat of the afternoon will be easier to get out of around dawn (and will cost less water -see Desert Survival). Soft sand on the tracks, churned by previous vehicles, is different from the sand in open desert where there is a definite top crust structure. This crust will be broken by the passage of one vehicle and following vehicles should not follow in the same wheel marks. On tracks the opposite can *sometimes* be true; a previous vehicle in some types of sand can favourably compact it for the one behind.

Salt flat -sometimes shown on maps as *sebkha* or *chott* -consists of a crust of unpredictable strength frequently disguising soft salty bottomless mud beneath. A bogging in this can often be forever. never drive at random over this. If there is a well used track it should be safe, but even a metre or so away from this can be disastrously soft.

## 6.8 CORRUGATIONS

In desert, savannah or bush areas, unsurfaced tracks which carry heavy traffic and are not regularly graded or scraped will often develop a surface of transverse corrugations. These parallel ridges, at right angles to the vehicle's path, can be as high as 10-15cms and spaced 30-60cms apart. Taken at the wrong speed they can nearly shake a vehicle to pieces. A 'best' speed, dictated by your vehicle's suspension rate and tyres, will result in at least the vehicle body and occupants having a relatively smooth ride though the springs and shock absorbers will be going through hell. This speed is generally 50- 70 kph (30-40 mph). Do not go much faster; remember you are virtually skipping from crest to crest and adhesion for braking or rapid steering response will be very much reduced.

## 6.9 WATER

After flash floods or en route through non-desert areas there may be times when you drive through water. People are easier to un-bog than vehicles so follow the recce-on- foot rule and wade through first to test the condition of the bottom (rocky? level? soft?) and also the depth. If the depth exceeds the height above ground of the fan, the ensuing under-bonnet spraybath could cause ignition failure; remove the fan belt, use WD40 spray on the ignition harness. Sometimes in marginal cases an old coat or sack over the engine (well clear of the fan) will keep the ignition dry. On Land Rover and Range Rover where one is provided, insert the wading plug into the clutch bell-housing and, on the latest 2.5 litre diesel Land Rovers a wading plug must be fitted to the drain hole in the bottom of the cam shaft belt drive housing. It is essential to remember this one as damage to the toothed belt and major engine damage can be the final outcome. On any vehicle, try if you can to block the axle breathers before wading. If you do not, the sudden cooling and contracting of the axle casings can cause water to be sucked in through the breathers and contaminate the oil. Finally always drive slowly in water to minimise spray and bow-waves. The magazine photographers would have you believe it should be one with the maximum commotion but, again, the media are wrong.

## 6.10 RECOVERY METHODS

**6.10.1 Shovels and Sand Ladders.** Shovels, aluminium sand ladders (5ft 6ins long and 13ins wide, rung at 5.5in pitch), a long tow rope, a high-lift jack and a winch are, in that order, the best recovery aids to free a stuck vehicle in the event that it has passed the stage of being able to reverse out of soft sand. The 'sand' ladders can be used in any conditions to put beneath or ahead of the wheels to give support and traction (see Annex A). Where it is necessary to make do, planks, or branches (e.g. palm fronds) can be laid down to support the vehicle. Often diagonal suspension hang-ups will occur where it will be necessary to dig away beneath one or both of the supporting wheels and lower the vehicle to a parallel-axle condition. Sand ladders can also be made to serve other purposes such as tables or sleeping platforms. (See Annex C).

**6.10.2 Towing and Pushing.** A long tow rope (long enough to enable the towing vehicle to be clear of the soft going -at least 50m) and a tow from an accompanying vehicle is, if sand ladders are not effective enough, the next most effective recovery method. The effort, however, must be co-ordinated -the clutches on the towed and towing vehicles must be engaged at the same time. Again an external marshaller can best give the signal. A tandem or multi-vehicle tow (See Annex B) is even more effective in the worst conditions and again co-ordination by signal is vital. Winches are slow, heavy, expensive and hard to match to road-wheel power and there is nothing to winch onto in real desert; however, they have their uses in recovering a thoroughly 'dead' vehicle or in emergencies such as righting a vehicle that has rolled over. The most surprisingly effective recovery aid, in conclusion, is the human shoulder. Despite their small horse- power output, a group of pushing people can work wonders, even making sure that a towed recovery will work first time. A Tirfor hand winch is light, cheap and versatile.

**6.10.3 Snatch Towing.** The advent of special ropes made of an elastic material has meant that the static tractive effort of the recovery vehicle can now be augmented by its kinetic energy in a 'snatch' recovery. A tow rope of 10-20 metres length is used and the towing vehicle starts with considerable slack in the rope -probably about 25%. Again using synchronised power on both vehicles, recovery of a badly bogged vehicle is spectacularly and elegantly enhanced by this method. One such rope is a Viking 3-strand, staplespun 1" diameter polypropylene rope made by British ropes of Carrhill, Doncaster (tel: 0302- 4010). Cautious experimentation before the expedition with the main variables -amount of slack and speed of snatch -are well worthwhile, starting with minimal slack and minimal speed difference. Needless to say only proper tow hooks and towing eyes should be used otherwise the snatch will cut the rope on any sharp edges (such as bumpers) and also helpers should *stand well clear of the rope* in case of breakage. On no account try snatch towing with other than special ropes; serious damage can be inflicted on both vehicles if inextensible ropes are used in this way.

### **6.11 TURBO DIESELS -STOPPING**

Due to the extremely high rpm at which turbo-charger impellers turn, most vehicle manufacturers using turbos lay down a procedure for switching off the engine. To ensure the turbo has slowed to minimum speed, switch off the engine only after 10 seconds of idling; to switch off with the turbo running at high speed means it would run-down from high rpm without positive oil pressure to the bearings. This could cause bearing failure in the turbo charger .

### **6.12 TRAINING**

For any expedition involving track or off -road driving, special sessions of driver training on rough country are really worthwhile -as well as enormous fun. (See Annex D). Special permission can nearly always be obtained for use of military training areas. It is far better to make your mistakes there first than with a heavily laden machine overseas. Finish off the session with an egg-and-spoon autocross (spoon held out of the passenger's window); it makes for just the kind of smooth effective driving required. Driving is tiring; on an expedition with a two man crew, have Driver A hand over to Driver B at mid day and vice versa next day thus ensuring a mid-session night's sleep in any 24 hour duty cycle. Off tarmac, never drive at night; it is too easy to hit unseen pot-holes and to get lost. On hard roads night-drive only if absolutely necessary; in inhabited regions of Africa, India and the Middle East unlit vehicles, bicycles and bullock-carts abound and compete with sleeping livestock for your road space.

## Annex A (Driving Notes)

## USE OF SAND LADDERS

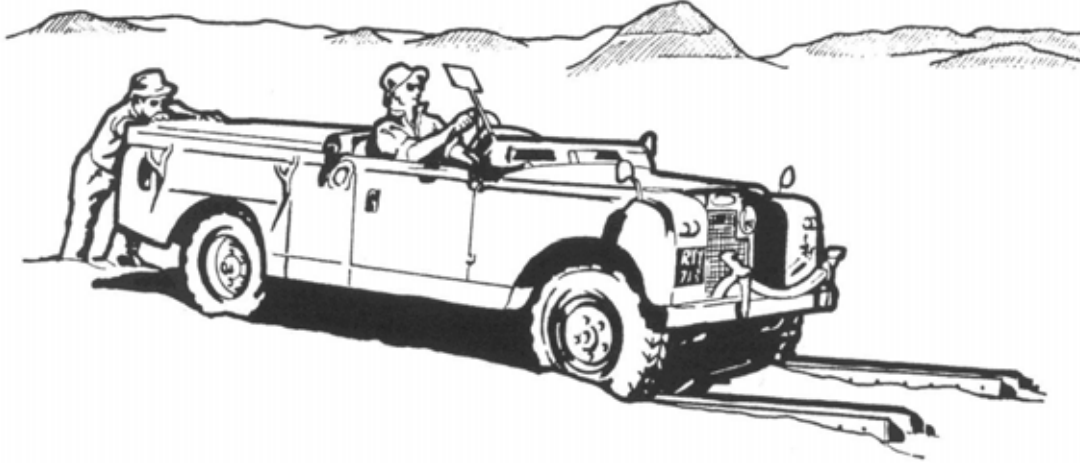

*"Avoid wheelspin, admit defeat early..." in a soft sand bogging. If the reverse-out policy has failed then the sand ladders will come into their own. By scraping away the sand in front of the wheels the vehicle can crawl onto the sand ladders and get enough forward momentum over their length to carry it on and out of the soft sand. Often the harassed 'crew' will have to rush round to the front of the vehicle in order to throw the ladders in its path again to preclude another sinkage. The Land Rover must keep going until it is back on firm sand; then the ladders must be dug out and carried to where it has stopped.*

A suitable sand-ladder for a Land Rover or Range Rover is 5 1/2 ft long, 13in wide with rungs spaced at 5 1/2 in



## Annex B (Driving Notes)

**TANDEM TOW RECOVERY METHOD**

The main application is in a very severe bogging, where the *first* tow vehicle cannot itself get onto the optimum firm ground or where a large vehicle has to be extracted by two smaller ones. A classic application is shown below (though the two ropes, for the diagram, are shown much shorter than they would normally be); a large vehicle has stuck on a loose stony hill where there is also loose sand. The large vehicle had not the power /weight ratio to climb the slope all the way and sticks near the top.

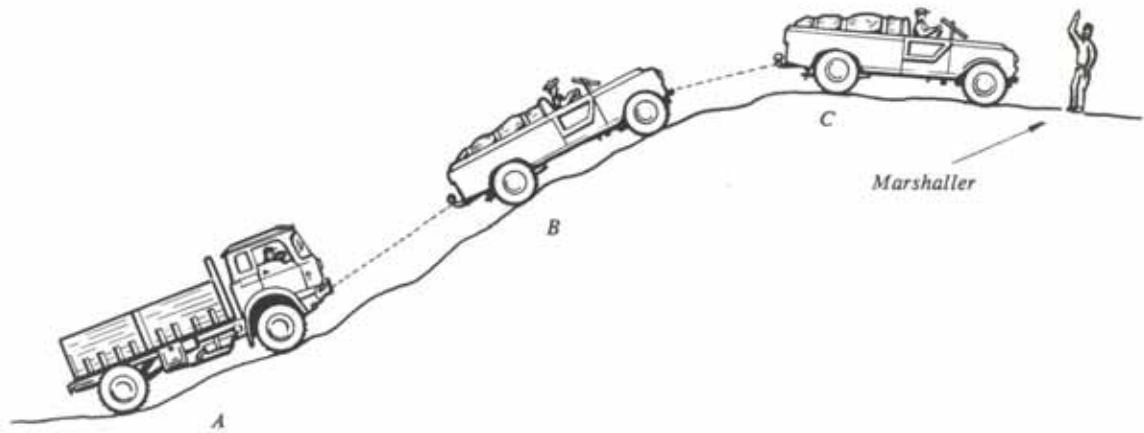

*Marshall first waves vehicle B forward till tow-rope A-B is taut; then he ensures tow-rope B-C is taut. Then, with all three vehicles' engines used and all in the best gear (low range, second gear, in this case in order not to over-torque the loose ground), he drops his arm and on the signal all three drivers let in their clutch. It is essential that all the drivers take their 'go' signal and 'stop' instructions from one man – the marshaller.*

## Annex C (Driving Notes)

**SAND LADDER TABLE**

*A simple modification with tubes weighing only a few ounces can convert a pair of sand ladders into a camping/cooking table or sleeping platform*

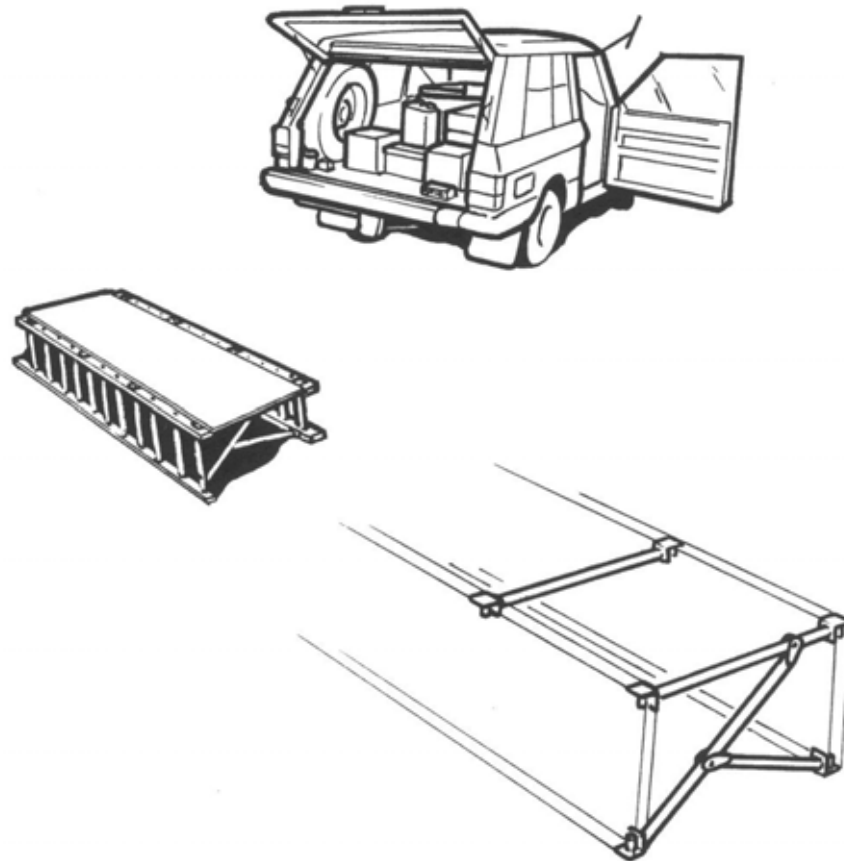

## Section 6 cont

### 6.13 DRIVER TRAINING PROGRAMME

Note: Assumes Series II Land Rover. This affects lesson 1 and 5. The principles of Lesson 5 can be applied to other vehicles including late Land Rovers and Range Rovers.

Abbreviations: 4WD = four wheel drive, H = high box, L = low box, 4L = 4th gear low box, etc.

#### LESSON 1. GEARBOX AND TRANSMISSION -SERIES II LAND ROVER

**BRIEF.** Re-cap on uses of all three levers. How, when and when not to engage 4WD; engage low only when stopped. Hand brake on only when stopped. Engage R, lor 2 quietly by touching 3rd first. Implications of differential on soft going. Synchro only on 3rd, hence need to double-de-clutch shown by arrows, (Series II Land Rover).

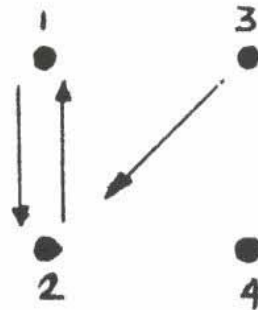

**Note especially the upward double from 1 to 2.**

**PRACTICE.** On level tarmac practice changes up and down both H and L boxes using all gears; double-de-clutch appropriately. When quiet on tarmac, repeat on bumpy ground.

#### LESSON 2. SLIPPERY CONDITIONS, POOR TRACTION.

**BRIEF.** Low surface strength plus low shear strength equals poor traction. Lowering tyre pressures helps the one, going into 4WD helps the other by halving horizontal stress. Also gentle right foot; smooth driving and high gears reduce horizontal stress. Analogous to jumping off a meringue. Practical application: use 4WD, lower tyre pressures, avoid wheelspin. If in trouble quit early and reverse out -rather than dig yourself in. Get out of 4WD and blow up tyres as soon as possible.

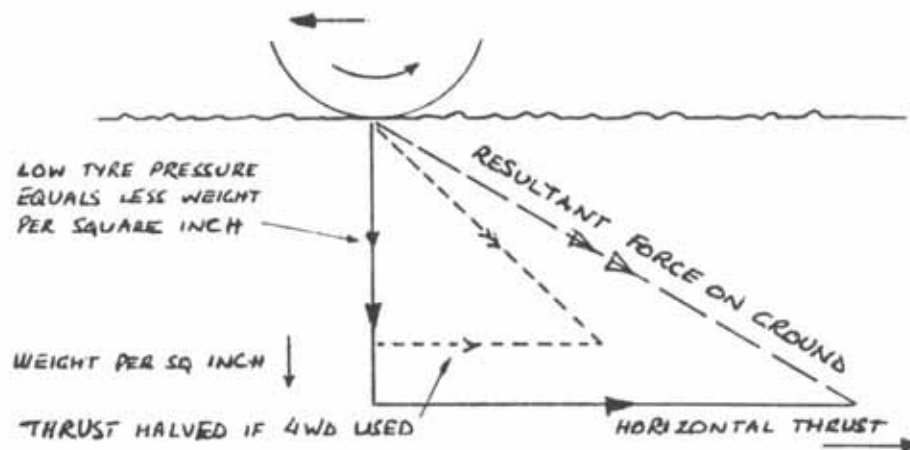

**PRACTICE.** Applicable throughout all driving cross country. Demonstrable on mud or grass steep slopes that use of 2nd gear gives better traction and less wheelspin than 1st.

### LESSON 3. HILLS UP AND DOWN.

**BRIEF.** Basic rules:

**On-foot recce** if in ANY doubt.

**Same gear down** a slope as you would use going up.

**Always go straight** at a slope, not diagonally.

Best traction when no wheelspin so don't select too Iowa gear. Emergencies: down:- de-clutch and gentle cadence braking; up:- quit early before wheelspin slews you, then dead engine reverse re-start.

**PRACTICE.** Demo effects of too Iowa gear, demo reverse re-start. Famil on steep ups and downs. Long test hills with rapid gear change to consolidate lesson 1.

### LESSON 4. OBSTACLE CLEARANCE AND TRAVERSING VERY ROUGH GROUND.

**BRIEF.** Lowest points diff drain plugs. Chassis cross member is strong point. Plough- through on soft ground only. Implications of approach and retreat angle when crossing ditches; beware tow hooks, silencers etc. Main principles on-foot recce first then marshaller using signs not voice. Driver watch marshaller not road. Minor dips to be taken diagonally to avoid both-wheels-at-once thump; but beware the frequent problems of diagonal suspension wheel spinning. Dig or remove obstacles in path. Make vehicle 'flow' over rough ground rather than jolt; use IL for enhanced control over large rocks, steps, etc. 4WD spreads transmission shocks anyway, always use on rough ground, corrugations, etc

**PRACTICE.** Cautious gully driving after on-foot recce. Practice marshalling procedures and threading between boulders, use sticks placed in the ground for practice first. Try low speed crawl over rocks in IL. Provoke diagonal suspension practice distant width- judging using two assistants with vertical poles.

## LESSON 5. LOW BOX TO HIGH BOX ON THE MOVE.

**BRIEF.** Very useful where stop and restart in 2WD not possible, e.g. softish sand.  
Remember  $4L = 2H$  approximately in terms of road speed for a comfortable change.  
Steps:

1.

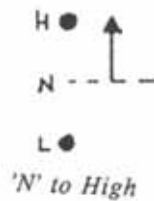
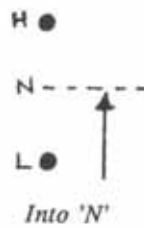
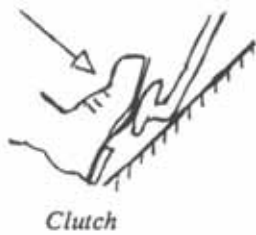

## LESSON 6. HIGH TO LOW BOX ON THE MOVE.

**BRIEF.** Basically a straight double-declutch operation remembering that the low ratio is about twice the high ratio and that therefore the revs for a given road speed will have to be approximately doubled when you change from the high box to the low box. Useful in a deteriorating terrain situation where stopping is not advisable or convenient. Cross over from high to low box when you have got down to 2nd gear high box and are then further losing speed for a severe obstacle to come.

**PRACTICE.** Practice in real conditions, is in bad going where the vehicle will decelerate during the double declutch. You will find it hard or impossible to do on tarmac.

## LESSON 7. RECOVERY.

**BRIEF.** With and without tow. With no tow, 'landscaping' usually inevitable but try reversing out before situation gets too bad. Admit defeat early rather than dig in with wheelspin. Self-recovery: lower pressures, off load, clear obstacles manually, brush-wood etc. under wheels for grip, third degree by jacking vehicle up and placing driveway under the wheels. Tow recover principles: long tow rope so towing vehicle on firm ground, co-ordinated use of power from both vehicles directed by assistant's signal. Tow points: beware axles and centre of bumper. Tandem tow: same principles but two vehicles pulling one. Stand clear of ropes in tension.

**PRACTICE.** Practice probably self generating. Demo recovery tow, tandem tow.

## LESSON 8. RULES FOR SAND DRIVING.

Special application of all the foregoing. On dunes don't brake, coast to a halt in case sand crust breaks. Very careful pull-away. Pie crust analogy, sand worse when previously traversed, hence avoid preceding tracks. Low tyre pressures, sand tyres, gentle right foot, use highest 4WD gear possible. Firmer going when damp. Cool dewy morning better than hot noon. Beware following winds, overheating. Recovery with sand ladders, psp or tow. Topography: avoid soft small hollows, beware dune crests, slip faces. On foot recce as necessary as always, post helper on dune lip if descending. DIBS mirror invaluable.

## EXERCISES

The following exercises consolidate lessons, especially d:

**Through the Gears.** Start in 4L, use all the gears and cross the finishing line at 25 mph. Technique: start in 4L, down to 3L, 2L, 1 L using minimum distance, up to 2L, then into 1H, accelerate hard in 1H and 2H, use 3H and 4H as late as possible. 'In gear' means foot off clutch. Marks deducted for noisy changes.

**Slalom.** Drive start to finish through alternate poles; then reverse through same course.

**Reverse into parking slot.** Reverse into 'kerb side' slot 1.5 times vehicle length, 6ft wide. Poles to be used as markers, wheels to be within 12in of kerb.

**Egg and Spoon Auto Cross.** Navigator holds egg and spoon out of window during marked out cross country route. Smooth driving counts. Very good value as an exercise.

## Section 7 : PHOTOGRAPHY

### 7.1 CINE FILMING

**Filming as a Source of Expedition Funds.** Probably the most common error in the context of filming expeditions is the belief that a film will readily generate money for expedition funds and that TV companies or cinema circuits will readily accept it. A clean living, noble minded, scientifically orientated expedition leader would be forgiven for concluding (after looking into it) that the world of marketing documentary films is hard, nasty, small-minded, parochial and short-sighted; a world where quality of production or the greatness or beauty of what it portrays are of less importance than who backed it, the union membership of who shot it and the size of attendant crew.

If the above is a surprise or taken as exaggeration it may still achieve its aims of alerting the expedition leader to what may be in store if an independent film is envisaged. Costs will be the other surprise. In one 3-month Sahara expedition the money turned over in producing the 52 minute film documentary was well over twice the whole expedition budget. Of that, post-shooting costs (production) comfortably exceeded filming costs up to the end of the expedition.

The best strategy for an expedition film, therefore, is to obtain prior backing and co- operation of the ultimate users -e.g. a TV company. The notes that follow are included as a guide to selection of equipment specifically for vehicle-borne expeditions in desert conditions based on the report of the expedition mentioned in paragraph 3 above.

### 7.2 REPORT (1975 Expedition)

#### 7.2.1 Film Equipment and Operations

A complete list of still, cine camera and sound equipment used on the expedition appears at Annex A. There was a subjective feeling that if the expedition was to succeed as a 'first', then there should be a film record. However, much harder commercial factors had to be considered before such an expensive and time consuming project could justifiably be embarked upon. The involvement of a sponsor was based on their having a copy of the film -or an edited version -as a soft-sell film for internal use showing their products at work. The existence of a film was also an inducement for other organisations to lend equipment. The film itself had to be a self -supporting, indeed profitable, prospect for any production company to become involved in since an outlay of not less than £6,000 was likely to be involved, plus a very large number of skilled man-hours over a period of a year or more. Professional editors, script-writers and post production facilities would have to be used. Advance marketing of the film idea was done by me in UK and France before departure. A small production company became interested in the film and agreed to cover production costs in exchange for marketing rights. For the four month period involved it was cheaper to buy and later re-sell the cameras rather than hire.

The size of the team precluded the luxury of a cameraman and sound man who did nothing else. These skills had to be superimposed on the people we had. The demands of leading the expedition, covering still photography and making a marketable film as well were severe.

#### 7.2.2 Cine Camera Equipment

Equipment had to be chosen and obtained and the selection process was to be far from straightforward. Conditions would be as hostile to camera gear as it is possible to imagine. Temperatures would range, in the shade, between maybe 4 and 44°C but this was nothing to the acquired temperature of a matt black object in the fierce solar radiation to be encountered. Vibration and bouncing of the vehicles would be ceaseless for something like 3.5 months and dust would be a continuous enemy. In newsreel photography, spontaneity and getting it as it happens are the main considerations. In contrast 'story' filming must be impeccable and no excuses are

accepted; the scenes can be controlled and the photography must be as good as it is possible to make it. In expedition photography have the worst of both worlds. The most filmable subjects are the spontaneous ones; you must be ready to grab the camera and be filming within seconds of being about your normal expedition duties. Yet the standard of filming - television standards are rising all the time - must be first class. What is more, in a small expedition you will have to steel yourself to grab the camera before anything else. Resist the temptation to rush to look or assist in other ways for the moment will be gone before you have the camera whirring. Financial survival of the expedition depended on such things and the time spent checking out a 'drama' situation was cut to the minimum.

The very best in quality was the aim and this meant expensive 16mm cine cameras, extra (wide angle) lenses, a fluid head tripod, sync sound and top quality negative film. Selection of equipment from-first-principles applied since the expedition was in the unique position of starting a small film unit from scratch; and one with special operating conditions and requirements. A camera with a power-zoom -variable speed for preference -and a wide angle lens became a necessity; also a film capacity of more than 100ft to preclude the need to change film too often in dusty conditions. The camera must be self-contained, not too heavy, not too expensive and above all ready to shoot the moment it was lifted from the box -no power packs, no slings or harnesses.

The prime camera chosen was the Beaulieu 16-news since it fulfilled the criteria better than any other. It offered a 9.5 to 57mm power zoom with variable rate, 200ft reel loading and handled well. A 5.7mm super wide lens was obtained as well which was invaluable for the occasional use it got. An even lighter 'grab' camera, usable as a back-up was needed, and the Canon Scoopic 16M complemented the Beaulieu and was kindly obtained on loan.

Bearing in mind its limited specification, the Canon was hard to fault. The Beaulieu offered more but was heavier and more expensive; it also had some ergonomic anomalies about it that took some getting used to. Overall, however, it was excellent for our purposes and worked well.

No camera is better than the steadiness with which it could be used and a fluid-head tripod for smooth panning and tilting was essential. A Ronford Baker F2 fitted the bill admirably though the fluid-head stiffened up in the heat and had to be kept cool and in the shade as much as possible. Another invaluable aid to camera operation enabling really rapid 'clunk-click' mounting of the camera was the Dufort wedge. Either camera could be mounted in about two seconds without any turning of screws or wheels.

Eastman negative Type 7247 16mm cine film was used; it yields good 35mm blow-ups too, a cogent point when marketing of the film is to be considered.

### **7.2.3 Sound**

First-principles resolution of the sound problem was also resorted to. Exotic machinery is pointless if the weak link in the chain is a tiny TV speaker or the quality of sound that a 16mm optical sound track can handle. Also, in the field the recording would be of voices, engines and petrol stoves so again hi-fi was not paramount. Ease of operation (there would be no separate sound man) and ease of protection from dust were essential too. Disregarding price for the moment the main apparent contenders, the Nagra and Uher were assessed. The Nagra had a needlessly high specification, was vulnerable to dust and ergonomically poor. The Uher shared these problems and additionally the one obtained on trial performed badly (hiss) and needed constant monitoring.

Looked at objectively, cassette sound had considerable advantages over reel-to-reel and offered all that was required in audio quality. The machine finally chosen was the Sony TC153SD (modern, light-weight equivalent is the Sony TCD5M -performance figures in brackets). Frequency response 50 to 12500 Hz DIN (30 -17000Hz) comfortably encompassed the audio requirements; SIN ratio



with FeCr tape and Dolby B at 53-58 db (59 db, Dolby off) compared favourably with the Nagra; cross-talk with a suitably attenuated cine pulse output was measured as about the same as the Nagra. Big simple controls and lead-access all on the front panel could be operated easily, and through a poly the ne sheet to keep the dust out. Sony FeCr 60 cassettes gave 30 minutes per side, minimising tape handling in the dusty conditions.

Considerable pre-expedition testing of the entire cine package was essential and proved satisfactory. The disadvantage of the vulnerability of the thin, slow-moving tape was offset by the ease with which it could be protected. Selection made itself almost entirely on performance grounds; the fact that, additionally, the Sony was half the cost of a Uher and a tenth of the price of a Nagra clinched it.

#### **7.2.4 Microphones**

The problem of microphone selection was even more confusing. Though many of my sync-sound situations would be 'set-piece' affairs where the 'stars' would know they were on tape and therefore available for fitting neck mics, a distant-sound directional mic facility would have been an advantage. 'Professional' advice was abundant and again so fragile was its technical base that an assessment was made based on what actually finished up .on tape, and above all the type of sounds that would be recorded. The great truths discovered about an exotic looking parabola mic and a Sennheiser 815 gun and 415 super cardioid (apart from their price) was that their directional qualities were only noticeable at high frequencies. Even at 8 KHz the 815 had an acceptance angle of around 30°. Out of doors test pieces were spoken in loft and 25ft circles around the microphone positions and when all the mics were compared on tape the Sony ECM 280 - compact and relatively cheap -was the choice. Sony ECM50 neck mics were used where possible in the high wind conditions that prevailed most of the time in the desert. An ECM 170 omni-directional mic was also taken.

There would have been much to commend a radio mic for sequences involving crews talking in approaching vehicles but, it was hard to get a demonstration and this equipment can be unreliable.

#### **7.2.5 Battery charging**

Germane to the whole equipment selection process was the problem of actually running it. Ni-cad batteries are very particular in their requirements and no two seem to be alike. A common recharging method direct from 12v DC would have been ideal but, apart from untried lash-ups which could have been unreliable, eventually a 240v AC source via a transistorised inverter was used. Caravan-type electric shaver invertors would work on some of the equipment but the Canon battery charger required nothing less than a precise 50 Hz sine-wave AC before it would work. A clumsy but effective sine-wave inverter by Valradio was thus used for all the battery charging. It was also expensive and not too efficient. Though claiming a 70% efficiency this only applied at full load; at the tiny current outputs demanded by the various units being charged it was using more than 5 amps from the Land Rover battery to put out only 37 watts. Thus the final inconvenience was that it could only be used for short periods during static parking and had to do most of the charging with the vehicle on the move.

#### **7.2.6 Protection**

Full protection against vibration, sun and dust and instant operability of the equipment when the lid was opened dictated design of the boxes for cameras and recorder . Samuelsons' aluminium boxes were used, polythene foam lined and with additional external cladding to minimise heat absorption by the aluminium itself. The recorder box was designed so that the unit could be run with the lid closed, thus facilitating unobtrusive 'wild sound' recording.

### 7.2.7 Film Storage

Film storage was in a wooden box, polystyrene lined, white painted and always kept in the shade. A picnic 'cool box' was used as a 'ready-film' box, taking the likely film needs for the day. The main box was left open at night to cold soak and not opened during the day unless essential. This way the contents kept cool for most of the time. Only where night temperatures seldom fell below 25°C was the system found to be lacking. There was no film damage or failure due to heat.

### 7.2.8 Shooting, Processing and Post-Production

As for the filming itself, the broad outline of the film had, of course, been established beforehand and it consisted of a main plot showing the progress of the expedition and the terrain it passed through with planned sequences to show the special work of each member of the team. At all times an 'edit-in-the-camera' approach was used where possible. When a sequence of a certain operation was to be shot, invariably a small shooting script with an exact shot order, length of shot, close-up or long shot was made. It *always* resulted in the filming being completed far more quickly and with less disruption than ad-hoc shooting. Shot sequence and content were recorded on a Philips 95 pocket tape recorder and subsequently transcribed with references to second camera, sound (if used) time, place, etc. Opportunity filming, of course, could not be planned, but where it occurred it too was written up on film data sheets. Exposed film went back to the UK as soon as possible after exposure. Feedback was essential and the production company informed the expedition of the results.

In use, the equipment worked very well. The Beaulieu was covered in aluminium kitchen foil to reflect solar radiation. The Sony recorder emerged from its final polythene bag in UK as pristine as when it left four months earlier. There had been, of course, nightly and painstaking cleaning of all cameras en route and meticulous use of polythene bags to exclude dust.

Subsequent production cost exceeded those of shooting and mounting the film project by a considerable amount due to the use of professional studios, editors and dubbing engineers. About 15,000ft of film was shot to produce material for an hour - a shooting ratio of about 7:1 - fairly good for this kind of film.

Cine equipment list is at Annex A.

## 7.3 STILL PHOTOGRAPHY

**7.3.1 Still Cameras.** On a similar expedition notes on stills photography were made as follows: Two Canon T90's and a Nikonos 5 were used as the basic equipment, one Canon for colour, one for black and white; the Nikonos was the 'sandstorm' camera and was loaded with colour. The finest grain film was used. The accessories, lenses and other equipment are listed at Annex B. The outfit (except Nikonos) was carried in foam cut-outs in a Samsonite ladies vanity case - light coloured ABS plastic of high resilience and low thermal conductivity and capacity. The box was rubber mounted (strapped down) within easy reach of the user at all times. The optics and construction of Canons are obvious reasons for their choice but the main points in their favour are the quick bayonet lens changing and the spot metering system that is essential for the high contrast desert light conditions where a vague 'centre-weighted' system would not be precise enough. The 15mm and 24mm lenses were used more than any others as they gave a feeling of being amongst the subject for close-ups and also convey precisely the immensity of the desert where distant shots were required.

The Nikonos is extremely rugged and also designed as an underwater camera. What is waterproof is also dust proof and sandproof and it was used for difficult-conditions photography, e.g. sandstorms as well as for 'grab-shots'; it was kept, set for prevailing exposure conditions, within arm's reach.

**7.3.2 Cleanliness.** As with cine and sound, minute attention to cleanliness was paid with the stills equipment. An anti-static gun, designed for records, was used together with a camel hair brush and blower. Film changing was, wherever possible done under calm conditions at night. The cameras, within the vanity case, were kept in polythene bags; when removed from the case the bags were not taken off until the picture was about to be shot. Ever-ready cases were not used as they afforded inadequate protection from shock, heat and dust.

**7.3.3 Picture Making and Pitfalls.** Content, viewpoint and interpretation are so subjective in pictorial photography that no valid comment can be made in a report or notes. The following, however, apply to record and pictorial photography and are worth considering:

*Metering:* Predominantly very bright conditions, when using TTL metering on an SLR camera -or any automatic metering -will lead to too small an aperture being used for good overall exposure. Since you want to portray the brightness in the scene, you do not want the meter system overcompensating for it. Readings must therefore be taken on a balance of light and dark subject matter or, ideally from an '18% grey' Neutral test card made by Kodak. An incident light meter is another solution to the problem. A spotmeter (Pentax Digital Spotmeter is invaluable where very demanding transparency shots are to be taken.

*Filling the Frame:* Keeness to fill the viewfinder sometimes leads to the abandonment of shots of distant terrain that would have conveyed considerable meaning even with a 50mm lens. Long Lenses: Very useful for mirage shots and the like, long (even circa 400mm) lenses are, even in the strong light conditions which enable short exposures to be used, very hard indeed to keep still enough for really good results. This is mainly due to wind which affects the camera even when on a massive theodolite tripod. (Normal 'amateur' tripods are usually not rigid enough for a 400mm lens). Raising the mirror on an SLR before exposure is a worthwhile precaution.

*Direct Sun:* Matt black camera equipment gets very hot very quickly in desert sun. Silver foil covers, multi-layered white handkerchiefs, sun hats over the camera and lenses are some ways of keeping heat load down when the equipment is in use.

*Film Temperature:* Given commonsense, colour film is amazingly tolerant of high temperatures. In the writers experience the tolerance limit was reached only once in 20 years -daily maxima of 40-45°C over a 3.5 week period with night lows of not much below 22-30°C. Under these conditions the film spoiled noticeably -pale overall colours, magenta cast in some transparencies and magenta 'blobs' in others. High temperature tolerance applies for short periods only. Electrolux make a small 12V lightweight cooler (called the RC30 'Sunnycool') which is ideal for film storage.

*Shooting for Audio Visual Presentations:* When shooting material for A V slide/tape presentations, this use must be in mind continually. Movie-sequence type shooting must be carried out in many instances and shot-to-shot dissolves planned.

### **7.3.4 Equipment**

Stills photographic equipment is listed at Annex B.

**Annex A (Photography Notes)****CINE AND SOUND EQUIPMENT****Ready Film Box** (used for stills film)

Masking tape, screwdrivers  
 Recorder  
 K2 -10 x 20. FP4 -10 x 20. HSE 4 x 20  
 3 Polaroid packs, 4 ND gelatine  
 4 exp meter batteries  
 Braun Charger, 2 pin adaptor  
 Long lead for Sony charging  
 Sony BP8 batt, ECM50 clips  
 mono din  
 Headphones, stills records  
 2 x  
 mono  
 55mm blue, 48mm orange filters  
 Dufort wedge nylon buttons

**Beaulieu Camera Box**

Beaulieu 16-news cine camera  
 Stills Film)  
 Agenieux zoom 9.5/57mm, hood filter  
 Kinoptic 5.7mm lens, hood. filter  
 Filters: 85N6 for zoom  
           85N6 & ND3 for Kinoptic  
 200mm lens, Pentax mount  
 Philips  
 Adaptor C-Mount/Pentax  
 &  
 3x conv. for Pentax lens to make 600mm  
 Dufort wedge and allen key  
 Remote and charging lead (12v)  
 Sync lead. 100ft reel  
 Plastic cover for battery  
 batteries  
 Lens brush/blower. Felt pen  
 Film data sheet, pen  
 Philips 95 Pocket memo recorder

**Canon Scoopic Box**

Canon Scoopic 16M cine camera  
 20x20  
 Dufort wedge and allen key  
 2 batteries. mains charger  
 Filters: CCA on: 4xND lens + meter  
 Lenshood. Lens brush/blower  
 100ft film, empty tin  
 Chest pad. Film data sheet

**Recorder Box**

Sony TC153SD Stereo Cassette  
 Mics: ECM280, ECMI70  
       2 x ECM50  
 Mic leads: ECM50 ECM280/170  
 Spare FeCr cassette  
 Mains charging lead 2 pin  
 Headphone plug - stereo-2 x  
 Headphone adaptor lead -stereo -  
 Head cleaners, cotton wool & felt  
 Cleaning fluid  
 Charging/mic bung for case

**Main Film Box** (Also used for

A. Steel box: 16 FeCr cassettes  
               Mic lead 280/170  
 Instruction books: Canon FI  
                       Gill. Scoopic. Beaulieu.  
                       Lunasix.       Flashgun.  
 Recorder. Sony Recorder  
 Mics. FeCr cassette  
 7274 – 40 x 100ft reels  
 AVO Meter, electrical smalls  
 12v soldering iron & solder  
 4xMN 1500. 5xMN 1604  
 (Mic. Philips)  
 TC153 wksp manual  
 85N6 gelatines  
 Polybags, Kleenex

B. K2 -40x36. 20x20. HSE -  
 FP4 -30x36. 10x20  
 Sixtino meter, TC153 strap  
 C. 7247 –1 5x 200, 3 x 100  
 Polaroid 10 col. 10 B/W  
 K2 –2 x 20; HSE 6 x 20  
 8 ND gelatines

Bic pens. stills film notebooks,  
Spare film data sheets.

**ABBREVIATIONS**

K2 = Kodachrome 25 )  
negative 16mm

FP4 = Ilford FP4 ) 35mm stills  
etc

HSE = High Speed Ektachrome  
manganese alkaline  
batteries

35mm stills

7247 = Eastman 7247

4 x 200 = Four 200ft reels

MN = Mallory

**NOTES**

Ready Film Box -soft insulated picnic 'cold box' with zip.

Beaulieu & Recorder Boxes -aluminium alloy. polythene foam cut outs Specially made  
by Samuelsons. London.

Canon Scoopic Box -supplied with camera. Painted white with upholstery paint.

Film box -wooden -36inx12inx10in. Painted white. polystyrene lined. Lockable. Steel  
box to protect cassettes from magnetic fields 10inx7inx4in

**Annex B (Photography Notes)****STILLS PHOTOGRAPHIC EQUIPMENT**

The following list shows equipment used on a recent small expedition in the Sahara, in the field for six weeks. There was no special photographic task.

**Photographic Gear****Samsonite ABS Plastic case 15in x 7in x 8in:** (Ladies vanity case, foam lined)

2 x Canon. T90 bodies	Canon Extender FD 2x-A & intrs
Lenses: 35mm, 24mm, 15mm, 200mm	Cable release
50mm macro	Canon flash shoe
5x orange filter (b/w)	Cokin filters, grads etc.
Small Bott lens cleaning fluid	6x red filter
Small paint brush	Blower

**Second Case**

Canon 300TL flashgun	Pentax Digital Spotmeter
Mini tripod	3x orange filter for Nikonos
Nikonos camera & instr bk	

**Misc:**

Tripod

**Helmet Box 12in x 12in x 12in:** (polystyrene tile lined)

Film: 30 Kodachrome 25/Fuji 50	Nikonos spare O-rings
21 Panatomic X/T -Max 100	3 spare Px625 batteries
Kodak Neutral Test cards	3ft flash gun extension lead
(18% grey)	Instruction books: Canon T90
Tempo marker pens	
Film record books	

## **Section 8: VEHICLE MAINTENANCE AND TOOLS**

### **8.1 PHILOSOPHY - PREVENTIVE MAINTENANCE**

The whole philosophy behind keeping the expedition vehicle fit can be summed up in two words - preventive maintenance. A really thorough, no-compromises service and overhaul *before* the expedition will payoff far better than trying to cope with problems as they arise in the field. Vitality allied to reasonable and sensitive driving (see notes of Driving) maintenance on the expedition will probably then be limited to the 20 minute nightly inspection and rectification of minor defects en route (see below and Annex A).

### **8.2 THE EXPEDITION MECHANIC**

A very great deal depends upon the team member taking on the task of mechanic - more even than would be expected. It becomes a manifestation of personality and sense of duty and tenacity. An eagle eye for detail, a mature ability to face facts, a total devotion to his task, an ability to influence his fellow team members, and as much mechanical knowledge as possible are some of the qualities he must possess. And he will have to display them during the pre-departure overhaul, for here no detail of the vehicle's condition must escape his notice, nothing can be glossed over, no hope-for-the-best attitudes adopted. The hard facts must be faced and acted upon when oil leaks, mechanical wear and the implications of remedial work necessary are being considered. Faults will not go away or cure themselves just because it will be expensive or difficult to fix them -any more than they will in the field just because there happens to be a sand storm blowing. It is in just these conditions that the old cavalryman's attitude of seeing to the welfare of his horse before attending to his own needs at the end of the day will payoff .

One of the first facts to face is the expedition mechanic's own experience and knowledge. He should know his own limitations, know and admit what he does not know and work with more experienced people in preparing the vehicle. But even here there is cause for considerable caution for many 'experts' in vehicle maintenance are jaundiced, ever open to expedient compromise and will rarely have the keen expeditioner's enthusiasm for thorough preparation. The crossing of this tightrope will be good training for those to follow. Do not accept glib assurances about something being 'alright' until you are personally convinced. There is no special mystique about engineering that puts it above commonsense explanations -whatever the subject. Be gently insistent.

### **8.3 PRE- EXPEDITION PREPARATION**

A new, run-in vehicle is the best way to start an expedition but budgets do not always stretch to this and a critical and thorough examination of the expedition machine must start as soon as it is acquired -even if it is new. A workshop manual is essential. Start at the ground and work up. Are the tyres right for the job and in top condition? (It is best to start with new ones). Wheel bearings - free, with correct end float? Brake drums off to check linings and operating cylinders, also hub oil seals. Are the axle cases bent? A ripple on the top surface will normally tell. Axle breathers must be serviceable, also differential housing oil seals and gaskets. Spring-eye and shock absorber rubbers and mountings, spring-to-axle U bolt fixings; check no spring leaves broken or unduly eroded by dust or rust. Prop shaft sliding and universal joints should not have excessive rotational or vertical play. Check underside of engine and gearbox for oil leaks - especially from around the clutch bell-housing drain hole since a slight leak there might indicate an oil seal failure in the rear main bearing and the possibility of oil getting to the clutch plate -disastrous if it happens in the field. Engine- and gearbox-to-chassis rubber mountings should be checked, also condition of all brake pipes and hoses (the clutch hoses and mechanism come into this too) and the security and condition of the whole system. If in any doubt about the exhaust system change it. Trying to remove it in the field when it is very old, fragile and badly corroded can lead to discovery of immovable or broken studs in the exhaust manifold when you will have neither the extractors nor spare studs.

Similar thorough visual inspection in the engine compartment should be carried out, again being on the look-out for oil leaks, condition of hoses, clips, wiring, fuel pipes and unions, exhaust manifolds, radiator. Unless virtually new renew water and heater hoses. A compression test on each cylinder, plug and carburetor condition and a check of engine tune on an electronic timer will be essential and leads to a full functional check of all aspects of the vehicle -steering, brakes, clutch performance and adjustment, engine power, gear boxes and transfer box controls. If in any doubt on shock-absorbers, renew them. It is worth fitting contactless electronic ignition if this is not already standard; the contact breaker type is susceptible to dust erosion and needs frequent re-tuning to maintain best power and economy in the field. The Lumenition type has been used in the Sahara at under-bonnet temperature over 82°C -a very severe test. (See notes on Vehicle Modification).

Careful reference should be made to the workshop manual for limits and settings - beware the know-all mechanic who uses figures that are 'OK for most engines'. The whole examination is little more than a methodical and commonsense check of the complete vehicle and should naturally be combined with a major schedule service (such as a 12,000 mile check) and oil and filter change. There may well be special grades of oil recommended by the manufacturer for high operation temperatures. (See notes on Vehicle Modifications regarding oil coolers and temperature gauges).

#### **8.4 NIGHTLY INSPECTION**

As with the overall philosophy, prevention is better than cure and a thorough nightly inspection of the expedition vehicle is essential in order to nip trouble in the bud and prevent actual failures. An end-of-day inspection schedule for a 1-tonne Land Rover is at Annex A, it can easily be modified with additions or deletions for any vehicle. The expedition must stop to camp wherever possible with sufficient daylight left to enable the vehicle inspection and routine maintenance to be done in daylight (about 1-1.5 hours before sunset).

A groundsheet, pair of overalls, old beret and pair of working gloves are invaluable for working on the vehicle; washing water and laundry are always a problem on expeditions and the Ragged Look for expedition folk went out of fashion years ago. Check tyre pressures and coolant level first thing in the morning when cold; don't fill the radiator to the brim as the coolant will only expand out through the overflow.

#### **8.5 TOOLS AND REPAIR KIT**

The toolkit must be assembled with an eye to the particular vehicle and the pre-departure work on it will have brought to light most of the 'specials' required such as extra long socket extensions, wry-neck spanners, special sized sockets, thin rimmed ring spanners and whether the vehicle nuts and bolts are metric, AF or a mixture of thread types. This is where a sober and painstaking scan through the workshop manual will pay off as it will indicate where special tools are required. This will also focus attention on what jobs can and cannot be undertaken in the desert.

Vibration and bad tracks can often cause fatigue failure of vehicle parts in the field and blacksmithing or sheet metal repairs may be called for. Hacksaws, files, metal shears, a large assortment of nuts and bolts and pop rivets, a rivet gun, large hand drill and set of drills should be taken with this in mind. A small clamp-on vice that can be mounted on a bumper or tailgate is well worth the weight. Two jacks are better than one, and if one is a high lift bumper jack it can often be used in recovery situations enabling sand ladders to be placed under the wheels. Tyre inflator - spark plug or electric motor type -will be needed frequently, as well as wide ranging repair kit for tyre tubes and the vulnerable side walls of radial covers. Use bags for the tools rather than steel chests; bags do not rattle.



## **8.6 SPARES**

The main spares kit needs disciplined and realistic thought. A thorough pre-expedition overhaul is better than a large spares pack; careful and infallible driving can lessen the en route requirement even more -springs and half -shafts, for example, are broken by drivers and do not fail of their own volition. (See notes on Driving re transmission brakes and half -shafts). However, hoses, fan belts, clutch and brake cylinder rubbers, electrics such as fuel pumps, coils, condensers, HT leads and alternators are less predictable and are worth taking. Carburet tor diaphragms, oil and fuel filters, air filter elements, electrical repair materials such as wire, terminals, 12v soldering iron, tape, fuses, bulbs should be taken, as well as a length of plastic tubing to use as a gravity fuel pipe with a can if the system fails.

A spares kit taken on a recent single-vehicle expedition is shown at Annex B and can be modified according to vehicle type and its particular strengths or weaknesses.

## **8.7 FUEL CONSUMPTION AND RECORDS**

Keep a notebook in which you record mileage, price of petrol bought, mpg, accidents and any parts failure or defects and remedial action taken. Note especially those items that will need attention at the next full servicing. (See notes on Fuel etc).

## **8.8 CLEANLINESS**

Finally cleanliness. Beating sand and dust on a hot-climate expedition may sound impossible but with care it need not be. Remember that every level-plug and filler cap removed carelessly can shake dust into the oil it is designed to keep in. A one-inch paint brush in a jam-tin half full of petrol should be used rigourously to clean down these or any sealing surfaces or parts before removing or working on them -or even to clean a suspected oil leak so that its condition can be noted next evening. It is again just a question of facing facts -a few grains of sand can destroy a bearing.

Cleanliness is especially important when mending punctures. Including a grain or two of sand between the inner tube and case of a hard-working radial tyre will ensure, as night follows day, another puncture later on. Cleanliness is perfectly feasible when fitting tyres; a large ground sheet on which to carry out the operation is essential.

## Annex A (Vehicle Maintenance Notes)

**END OF DAY INSPECTION -1- TONNE LAND ROVER**

**Begin in cockpit, then clockwise from front of vehicle -Use torch**

**NB** Do not check coolant till cold.

Remove Engine Cover  
Fan and compressor belts  
gaiters  
Alternator belts  
Coolant hose clips (13)  
Ignition harness  
Petrol unions  
Oil leaks  
ends  
Water pump, leaks  
bushes  
Radiator rear face  
Radiator front face

**(Leave engine cover off -oil check later)**

**Cab**

Battery:  
    Leads secure  
leaks, bushes  
    Wingnuts tight  
bottom  
    Fluid level  
Engine intake clear  
Pyros, compass, light ok  
fretting

Hydraulic fluid, front brakes **(L)**  
Hydraulic fluid, rear & clutch **(R)**  
Brake pipes at servo and cylinders  
Pipe unions on bulkhead **(3)**  
sidewall  
Brake and side lights  
leaks  
Flashers  
Brake failure light  
bushes

solenoid, leads

**Front Grill Area**

leaks  
Pipe unions, outer ends **(3)**  
play  
Coolant hose junctions **(8)**  
Diff lock suction pipes secure **(3)**  
Steering relay ball joint gaiters

Under Front Bumper  
Track rod, drag link ends,

Oil-filter-to-cooler pipes  
Steering relay  
Hydraulic pipe on axle  
Axle breather  
Anti-roll bar mountings,

Road spring front eyes,

Axle U- bolts  
Diff drain and filler plugs  
Swivel pin housing seals  
Brake pipe jump hose  
Brake pipe to back plates  
Brake pipe junctions  
Steering damper  
Tyre inner sidewalls  
Front shock damper,

Brake back plate, leaks at

**OS Front Wheel Arch**

Steering box, leaks,

Engine side panel off:  
    Ignition harness  
    Manifold  
    Hose  
Tyre sole and outer

Rear of shock damper,

Swivel pin housing, filler  
Road spring rear eye,

Starter motor and

Rear of oil pump, leads,

Front prop shaft, gaiter,

Front diff nose seal  
Exhaust pipe

Hydraulic union on cross member

### **Under Engine and Offside**

Sump bolts  
 Bell housing drain plug  
 Gear box, transfer box  
 Diff look vacuum pipes (2)  
 hoses  
 Hand brake mechanism  
 sidewall  
 Fuel tank. Leaks, damage  
 Rear prop shaft, gaiter, play  
**(hand brake off)**  
 Rear diff nose seal  
 Road spring. front eye, bush  
 Rear shock damper. Bushes, leaks  
 Tyre inner sidewall  
 Brake back plate, leaks at bottom  
 Brake pipe junctions  
 Brake jump hose

### **OS Rear Wheel Arch**

Tyre sidewall and sole  
 Rear light harness  
 Tail pipe secure

### **Rear of Vehicle**

Road spring rear eyes. OS & NS  
 Exhaust pipe and silencer  
 Diff drain and filler plugs  
 Load sensing linkages  
 Brake pipe on exle. all junctions  
 Tyre inner sidewalls  
 Axle breather hose

### **NS Wheel Arch, Rear**

Rear light harness

### **Under Nearside**

Tyre inner sidewall (**rear tyre**)  
 Brake backplate for leaks  
 Rear shock damper. leaks. bushes  
 Road spring front eye. bush  
 Exhaust silencer and pipe  
 Compressor tank and hoses  
 Small pipe on top of tank  
 Gearbox oil filler plugs (2)  
 NS exhaust pipe  
 Clutch slave cylinder and hose  
 Road spring rear eye. bush  
 Front shock damper. leaks. bushes  
 Swivel pin housing. filler  
 Tyre inner sidewall (**front tyre**)  
 Brake backplate. leak at bottom  
 Brake pipe unions

### **NS Wheel Arch, Front**

Engine side panel off:  
 Ignition harness  
 Exhaust manifold  
 Compressor

Tyre sole and outer

Headlight wiring harness

Engine Compartment  
 Check engine oil  
 Replace engine cowl

Next morning:  
 Check coolant level  
 Tyre pressures

**Annex B (Vehicle Maintenance Notes)****SPARES AND REPAIR KIT**

The following list, based on a desert expedition involving a single Range Rover, can be used as a guide -not exclusive or exhaustive -to spares requirements.

**Vehicle Spares, Tools, Tyre/Repair, non-boxed items****Box 35 x 14 x 10in**

Xenon timing light, tacho-dwell meter	Ignition coil
Carb Spares (jets, diaphragms, gaskets)	Oil filter
Fuel pump	Distributor cover
2 x air filter elements	Speedo head
Alternator	Speedo gearbox gear
HT cable	Spare lumination kit
Set plugs	3 x fuel filter elements
Speedo cable complete	Gasket
Speedo Angle drive	3 fan belts
Main hoses top & bottom (coolant)	Clutch master/slave
repair kit	
Clutch jump hose	Hub brg tab washers
Front tracta joint seal	3 wheelnuts
Window winder handles -2	Spare fluorescent tube
15ft 0.25in plastic tube	Padsaw
Hacksaw and 3 blades	Avo Multimeter
Large handbrace drill	
Pyrotechnics (rescue): 4 smoke/flares, 3 x 900ft rockets, 2 pkts mini-flares, 1 parachute flare, 2 Sowester orange smoke.	

**Box 21 x 9 x 10in (Vulnerable items after line 6 in Cadbury's Smash tins)**

5 500ml squeeze packs 90EP oil fluid	Plus Gas dismantling
0.5kg tin Castrol LM grease	WD40 with long nozzle
1kg tine Tricholethyene cleaner/tyre buffer	2kg misc nuts and bolts
Pop-riveter	Pop rivets
Sheet metal nibbler	G-clamp
Electric connectors	Insulation tape, plastic, 3
rls	
Hermetite Gold sealer	3 tubes Bostik No I
Araldite Rapid	Electric wire
Araldite Normal	Magnet
Jubilee clips (0.5, 1.5, 2, 4in) centre-pop.	Drills 3/32-32/8) chisel,
Spare bulbs: Stop/tail 5/21 w x 2, indicators and reversing 21 w x 2, day-notice lights 21 w quartz x 1, side light x 1, interior festoon 6w x 1, interior bulb 10w x 1	

**Box 17 x 15 x 6in**

3 Michelin 16J9 7.50 x 16 tubes cmp )	Tyre inflator hose (glove
Tip-Top tube patches 10x No5, 30x No 3	Emery paper, wet and dry
250ml Tip- Top Vulc fluid (for tubes)	Tip- Top cover repairs 10
RX50	

1 litre Tip- Top repair filler A & B  
 cement  
 Roughners, bent rasp, buff  
 Michelin rubber lube grease  
 bond  
 Valve caps (Glove compartment)  
 2 tins Lockhead Universal 329 hyd fluid  
 Plastic padding ( 1 hard, 1 elastic)  
 12vDC soldering iron  
 2 tubes Dukhams Palmit

**Other tools etc, not boxed:**

Workshop manual and parts book, owners manual  
 2 tool bags with tool \*  
 Metric)  
 2in vice and clamp  
 Jerry can dipsticks  
 fuel tank  
 Spare elastic cord/hooks  
 hacksaw  
 Radiator sealant (Gloves compartment)  
 4in x 48in 18swg alloy -4 strips  
 Roll lashing tape 2in  
 Second jack  
 kit)  
 Inspection lamp (fluorescent)  
 veh)  
 Torch  
 2  
 Footpump  
 Plastic syphon for oil +  
 lamp  
 2 gall steel can for engine oil

**Recovery gear**

2 x shovels  
 Capstan winch  
 Towing rope and shackles

250ml Tip- Top special  
 (for covers)  
 250ml Tip- Top Special  
 (filler adhesive)  
 5 Schrader valve cores  
 3 x 18in tyre levers  
 Holts fibreglass repair kit  
 with Cataloy

1 set sockets (AF, Whit,  
 Metric spanners  
 Syphoning tube for aux  
 Shears, files, small  
 (in tool bag)  
 Distilled water  
 Palmit (glove comptmt)  
 Spare ign keys (in office  
 Spare door key (taped to  
 Wood blacks for jacking -  
 Grease gun  
 Everready Motormate  
 2 x 5.5ft aluminium sand  
 ladders  
 50m winch rope

\* Comprise normal comprehensive owner-mechanic toolkit evolved for the vehicle

+ Available from ships chandlers. Invaluable for filling gearboxes with combined level/filler plugs.

## Section 9: VEHICLE MODIFICATIONS AND TYRES

### 9.1 CATEGORIES

Most modifications fall into three categories and it helps to consider them in this light when deciding what, if anything, needs to be done to the vehicle on which an expedition is based.

**Vehicle Function.** Modifications to safeguard and enhance the performance of the vehicle.

**Crew Function.** Ditto for the crew -generally these affect crew comfort.

**Expedition Function.** Special fitments related to the role of the expedition, mounting of special instruments, tie-downs for equipment, lockable compartments etc.

### 9.2 VEHICLE FUNCTION MODIFICATIONS

These will vary widely according to the vehicle, the terrain over which it will be used and the time of the year it will be operating. Based on an average UK-based Land Rover, the following list will readily read across to other vehicles from 4x2 pickups to a 4-ton Bedford truck.

**9.2.1 Oil Temperature Gauge and Oil Cooler.** The former is essential, the latter less so - provided the vehicle is stopped to cool when the oil temperature is high. Remember an oil cooler only cools engine oil; transmission oil gets very hot too so some thought must be given to this when driving.

**9.2.2 Air Filter.** Requirements differ with vehicles. The basic oil bath filter on a Land Rover is excellent. The latest large paper element type is even better. A raised intake pipe with 'top-hat' swirl separator on top can be added for exceptional conditions of dust. Look at each vehicle for strengths and weaknesses here -e.g. the unbelievable wheel-arch air intake on the standard I-tonne military Land Rover (easily modified to inhale via the battery compartment) or the forward-pointing intake snout in a Range Rover (modified with Land Rover swirl separator over an extension on the end).

**9.2.3 Petrol Filter.** Many vehicles already have one. If without, consider fitting one with a renewable element such as fitted to the Range Rover .

**9.2.4 Ignition Contact Breakers.** On the Rover V8 engine these are short lived even in the UK. With powdered dust on desert tracks they are much worse due to attraction of the dust into the distributor head; the same problem affects many vehicles. Contactless electronic ignition is highly recommended. The Lumenition system has worked faultlessly on a Range Rover over some 12,000 miles and engine timing is maintained throughout.

**9.2.5 Fan.** In the writers experience add-on electric radiator cooling fans such as the Kenlowe not only perform inadequately in really demanding conditions but the mounting can come loose on corrugated tracks and put the fan into the radiator core. Some vehicle manufacturers offer a fan with more blades for hot climate use; this is far the best bet. Most standard fans are perfectly adequate.

**9.2.6 Battery Master Switch.** This involves heavy cabling but is a useful safety (and anti- theft) device in the event of electrical fires. Potential faults in old vehicles seem to be brought to a head by dry, desert operations. The writer has experienced three electrical fires in Land Rovers on desert expeditions -saved in two cases by the battery master switch Build standard and electrics on post-1983 Land Rovers is enormously improved; more fuses are provided too so a battery master switch is not essential for safety.

**9.2.7 Tachometer.** Not in the luxury class it may seem, but useful for a sensitive driver to avoid over-revving and, surprisingly, under-revving by slogging too long in too high a gear.

**9.2.8 Sump Guard.** Not necessary on Land or Range Rovers because the axle casing protects the engine sump but it may be useful on some 4x2 vehicles to guard against rock damage. It is essential to consider sump cooling before fitting one since ambient air over the sump is usually the only way engine oil is cooled. Perforations in the guard or a duct to funnel air between it and the sump may be solutions. Fit an oil temperature gauge as well anyway.

**9.2.9 Fuel Tank Protector.** Aft-mounted fuel tanks (Range Rover, 6 cyl Land Rover and many pick-ups) can be very vulnerable to tail-down bumps resulting from thoughtless driving up steep banks. Some manufacturers (e.g. Rover) provide a tank guard as an option. They are rather heavy but are worthwhile.

**9.2.10 Propeller Shaft Gaiters.** The sliding joint of a prop shaft is very prone to up dust sticking to grease after extension -happening all the time on undulating tracks. Spline wear and shaft vibration develop quickly unless a concertina gaiter is fitted between the two parts to exclude dust and mud. Standard option on Rovers; the same gaiter would fit many other vehicles.

**9.2.11 Tracta-Joint Gaiters.** The steering swivels on all Rover and Bedford models are vulnerable to dust and sand sticking to or getting under the wiper seals. Leather gaiters are available for Rovers and can be made for other vehicles.

**9.2.12 Tyres.** As mentioned elsewhere in these lecture notes, the Michelin XS is the best desert tyre made -by reason of its radial construction, and brilliantly conceived tread pattern. Regrettably they are not available in a wide variety of sizes but a small degree of oversize fitting is acceptable - e.g. fitting the 7.50 x 16 onto a Range Rover or short wheelbase Land Rover. In the former case the body panels at the wheel arch will have to be trimmed back. Oversize tyres cannot be fitted to all vehicles with impunity as they will affect the torque loading on the transmission (and thus its fatigue life) as well as the overall gearing of the vehicle -including the accuracy of the odometer (see notes on Navigation). If an XS tyre is not available, a radial tyre with a moderate tread profile - i.e. not a 'knobbly' -is preferable to a crossply. Sidewalls on radial tyres are thin and thus vulnerable to rock damage and careless driving. Driving must be adjusted accordingly and a 'sidewall awareness' developed.

**9.2.13 Roll-Over Bar.** If vehicles such as Land Rovers are used 'topless', with windscreens etc removed to save weight, then fitting a roll-over bar is a wise precaution. Steel tube of about 2in diameter should be used. It is essential that it is adequately anchored to a strong point on the body (or chassis) and that it is stressed to take impact from the front as well as from the side. (see Annex C).

### 9.3 CREW FUNCTION MODIFICATIONS

These are mostly aimed at crew comfort and habitability of the cab:

**9.3.1 Ventilated Seat Backs.** Few production vehicle seats are sufficiently ventile to avoid sweaty discomfort in hot climates, though fabric upholstery on more up to date vehicles helps enormously. Seat/back pads of plastic mesh and sprung wire can be bought and ensure .75in of air between the seat and occupant. Alternatively some of the thick sheepskin-type seat covers are also effective.

**9.3.2 Extra Floor Insulation.** Effective against noise and heat (especially in Land Rovers) is .Sin felt or the special under floor material offered by car interior silencing firms.

**9.3.3 Double Roof.** If a hard-top Land Rover is used, a double roof is very worthwhile. Even with one fitted the interior temperature will be very high for most of the day. A similar solar shield, with air gap, is worth considering for any metal-top vehicle.

**9.3.4 Extra Ventilation.** Van roof ventilators with opening flaps are worth considering for any metal-top vehicle. If workshop facilities permit, a top-of-the-windscreen scoop can be devised to duct face-level air to the interior through eyeball vents. On Land Rovers the side windows are easily removed by undoing two nuts. (See para 4h and Annex A).

**9.3.5 Interior Lights.** Caravan-type fluorescent tube interior lights are invaluable, especially one near the back door/hatchback of a vehicle to use as a camping and cooking light.

## **9.4 EXPEDITION FUNCTION MODIFICATIONS**

A complete list of these modifications is impossible without reference to the exact nature of the expedition. The following will be common to most:

**9.4.1 Sand-Ladder and Shovel Racks.** External mounts with over-centre clips afford ready access, easy shedding of residual sand when re-stowed and, with bicycle locking chains, straightforward security in inhabited regions.

**9.4.2 Winch.** Most winches are heavy, expensive and suited more to mud recovery than desert boggings. In general better to do without and (see notes on Driving and Recovery) use sand-ladders or towed recovery.

**9.4.3 Internal Tie-Down Cleats.** Lashing down the vehicle load is essential to avoid damage to vehicle and equipment. Loading up the day before departure will not do; a detailed loading plan must be made (main weight forward) and appropriate tie-downs and strapping worked out. Lashing cleats are available on the Land Rover parts list.

**9.4.4 Cash/Valuables Box.** A standard office cash box bolted under the bonnet with bolts accessible only from inside the box is a valuable modification.

**9.4.5 Special Equipment Mountings.** Careful thought must precede the loading of valuable or delicate expedition equipment such as gravimeter, theodolites, radios, cine cameras etc. The mid-wheelbase point gives the gentlest ride so this region, if possible, should be chosen for mountings. Anti-vibration mounts (Govt-surplus instrument/radio shops will have them) can be used but beware rubber-only mountings; without the essential damping such mounts can actually give equipment a rougher ride than being bolted direct to the floor. If in doubt, a light plywood box with small poly the ne bags full of polystyrene chips or pellets will give a cushioned and reasonably well damped ride to delicate equipment.

**9.4.6 Jerry-Can Mountings/Roofracks.** These are almost invariably a symptom of trying to squeeze quarts into pint pots -since their adoption usually means the vehicle maximum design weight (GVW) is being exceeded -external jerry can mountings and roofracks should be avoided in any serious expedition. Firstly the GVW must never be exceeded, secondly the aim must be to keep the load within the wheelbase thus keeping pitching and rolling moments low and within the routine capability of the shock dampers. Where the vehicle has a low-density load inside on seats - such as people -and a roofrack load can still overall keep within GVW, then it may be acceptable. Or where the main load is bulky and not too dense, very light bulky items such as sleeping bags or empty cans can go on the roof. Provided there are at least two or three people in the vehicle, a trailer is a better solution than external racks. (See Notes on Vehicles for Desert Terrain).



**9.4.7 Moveable Spotlight** A scuttle- or windscreen-pillar-mounted spotlight (or the currently available plug-in quartz iodine handlamp) is invaluable when caught out trying to find a camp site after dark and for general camp use.

**9.4.8 Pre 1984 Land Rover External Window Stowage.** Having removed the door windows on a Land Rover for extra ventilation, stowing them can be a problem. This can be achieved using the outside of the door panel as a rack. (See Annex A).

**9.4.9 Dibs-Mirror.** (See Notes on Navigation -Annex B and pg. 69). Requires thought and care if the ability to reflect the sun onto the ground ahead of the vehicle with the sun in any position is to be achieved. Most demanding is when the sun is near to setting in a 7 o'clock position to the driver -also a set of conditions where a DIBS-mirror can be most needed. A single-arm door-pillar mirror (flat) off a large van or light truck is the best starting point.

**9.4.10 Sun Compass Mounting.** Demanding again since visibility by the driver must be achieved as well as easy on-the-move access for re-setting the shadow marker. Additionally the compass must be free from interference from the shadows of other equipment - including the crew (See Annex B).

**EXTERNAL STORAGE FOR LAND ROVER WINDOWS (pre-1984)**

Diagram shows stowage for Land Rover windows, removed for better ventilation, on a 'take along' basis.

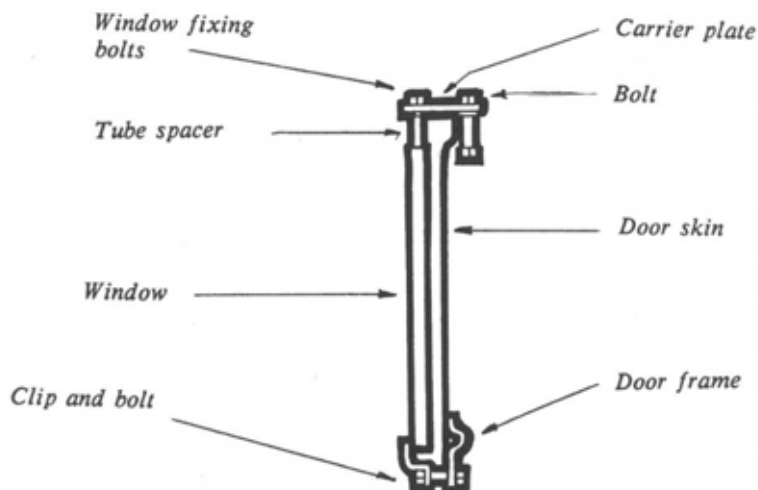
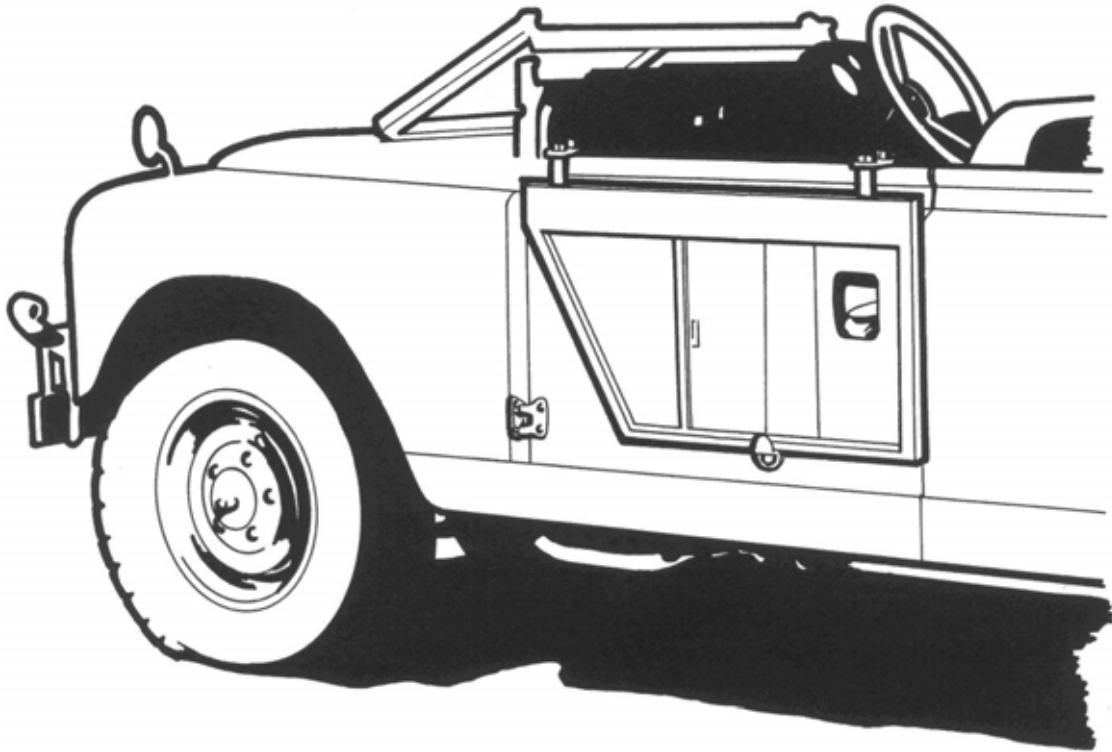

## Annex B (Vehicle Mods Notes)

**SUN COMPASS MOUNTING**

*Sun compass mounting – close to the ideal – shown on the 1-tonne military Land Rover. Visibility is good for both driver and passenger.*

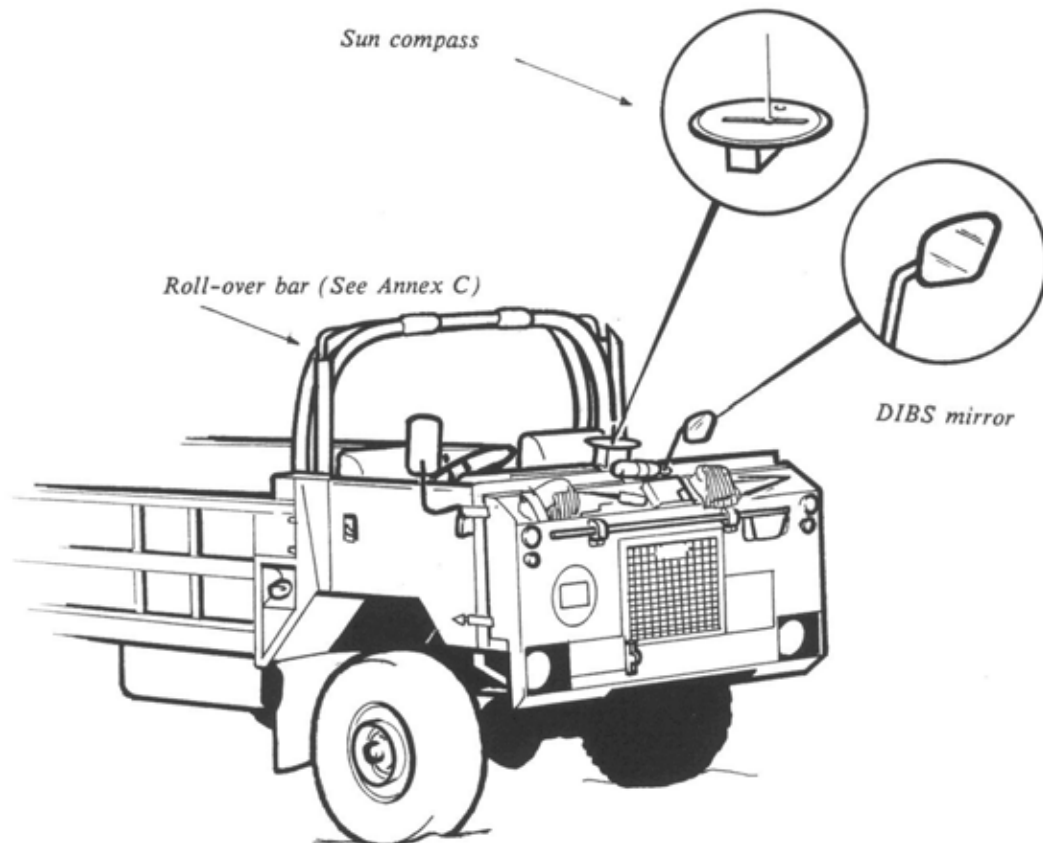

*Use and mounting of a sun compass – on any vehicle – is greatly enhanced by removal of windscreen*

## Annex C (Vehicle Mods Notes)

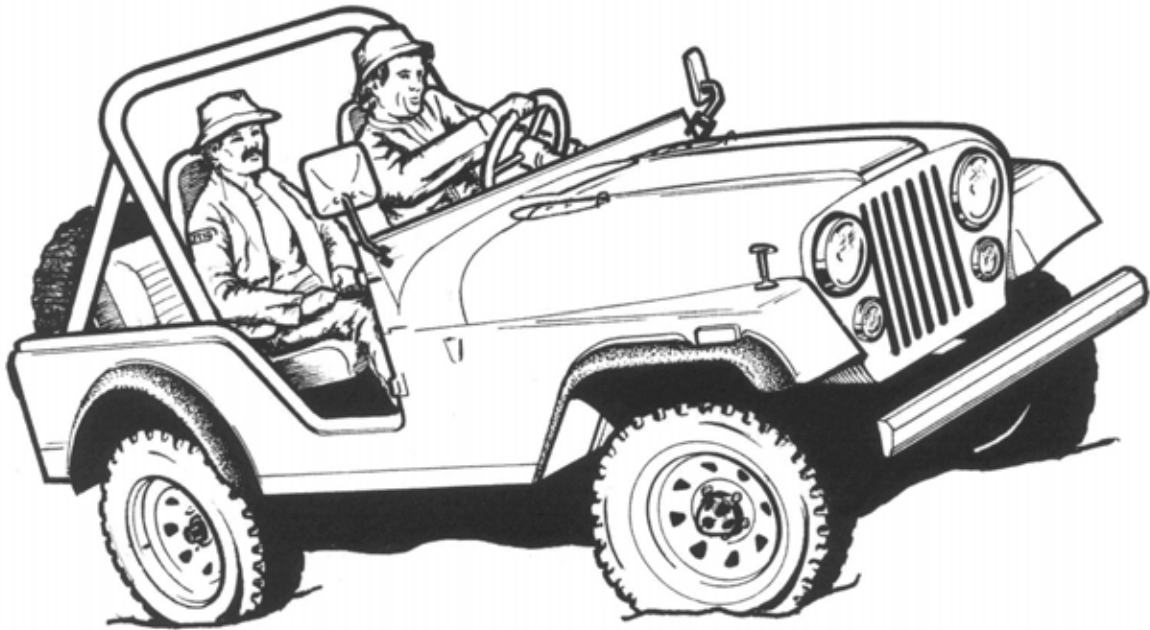
**ROLL-OVER BAR**

*Roll-over bar shown on US 'recreation vehicle' CJ5 Jeep illustrates well the principle of fore-and-aft bracing as well as lateral strength. Installation is a wise precaution in any vehicle to be used with upper bodywork removed to aid visibility and save weight. Compare with roll-over bar shown in Anne B which, though amply strong in roll, is inadequately braced for-and-aft.*

## Section 10: MEDICAL AND SURVIVAL

### 10.1 GENERAL PHILOSOPHY

These notes are not written by a doctor. They give a practical and limited 'user view' of expedition medicine as applied to desert environments. It is important that medical knowledge is regarded in the same light as any other specialisation in an expedition context, that it be stripped of its mystique, that it be approached with the proper thirst for knowledge and humble regard for truth that makes any subject the slave of ordinary logic and what we regard as common-sense. Again, as with any other subject, the 'student' must, in his worship of Truth, be alert always to what he does not know. The reference books listed in the bibliography, treat medicine in just such a light and the expeditioner is spared the 'you would not understand' approach luckily becoming less prevalent in the medical profession these days.

Desert expedition medical problems are likely to fall into the following categories:

- Heat/water-balance related problems.
- Gastro intestinal problems.
- Stress.
- Normal medical problems -little different from those manifest anywhere else.

These notes are naturally limited in scope; they will deal mainly with first-hand experiences with some referenced information included as well.

### 10.2 HEAT AND WATER-BALANCED RELATED PROBLEMS

A basic appreciation of the physics of heat transfer and the phenomenon of cooling by evaporation is a great help in appreciating nearly all aspects of heat and water-balance related problems.

Steaming soup in a large soup plate will cool more quickly than in a jug because there is a larger surface area from which evaporative cooling can take place. Water (steam) is lost in the evaporation process. The human body uses a porous skin and evaporative cooling (sweating) to keep cool (i.e. to maintain a constant 36.9°C body temperature in the face of what would otherwise be a heat build-up due to energy expenditure); in doing so, water is used. The greater the amount of heat to be shifted (or the more energy expenditure during the heat of the day) the greater the loss of water. If the ambient temperature is above the body temperature then, to prevent body temperature from rising, water is lost through evaporative cooling even when standing still. In any emergency which becomes a matter of survival, there will almost invariably be a water shortage too so its conservation is vital; extracting a severely bogged vehicle will cost less water if the work is done pre-dawn (the sand is firmer then anyway); any walk for help should be done at night, resting in the shade during the day; loose, long sleeved shirts and trousers will allow enough evaporative cooling but not lead to the wasteful loss that shirtless bodies in low desert humidities incur. Remember the slow steady work rate of desert dwellers and the slightly more humid and therefore evaporation-limiting 'micro- climate' with which their loose robes surround them.

In temperatures over about 42°C high winds, sand storms or riding shirtless in a fast moving vehicle will promote high heat-gain by the human body from the air through conduction (contact with hotter substance, like putting a kettle on an electric hot-plate); considerable and excessive water loss will result from combating this thermal onslaught and clothing must be donned to limit the heat-gain. This is the opposite of the wind- chill factor so well known in winter survival but is avoided by the same means - insulation. The difficulty in detecting excessive sweating is that, in the exceptionally low humidities prevailing in true desert, sweat evaporates instantly and the skin appears to remain dry all the time -unlike the sweat-soaked shirt and streaming face that manifests itself in hot-wet jungles.

In survival conditions, remaining in the shade and limiting heat-load by use of light coloured clothing, hat and possibly an aluminised 'space blanket' shelter will also reduce the amount of heat transfer the body has to combat by evaporative cooling. A 'space blanket' will be found a useful aid in general camping as well.

The simple relationship, covered in the above paragraphs, between heat -be it ambient temperatures, workload-induced or a combination of both -and the human body's water requirement now makes the mechanics of heat and water- balance disorders easy to understand. The pure laws of physics determine that a body (human) of given mass, subject to a given heat load, will, in order to maintain a constant 36.9°C, have to receive a certain amount of cooling -no more and no less.

Nature being what it is, the human body is equipped with a supremely elegant thermo- regulatory apparatus that gives different areas of the body different capacities for heat transfer and then arranges to switch sweating on and off until precisely the right body temperature is achieved. Deprive the body of this apparatus (by working in a rubber suit or not replacing water sweated out) and you invite trouble. There is thus no such thing as a 'tough guy' who can do this with less water than anyone else; if your water balance drops then, in general and in time, symptoms of dehydration will manifest themselves.

Normally the order is roughly:

Thirst

Headaches

Dark coloured urine

Extreme fatigue

Nausea

Dizziness

Cessation of sweating and rise in body temperature -i.e. thermo regulatory failure.

This latter is frequently the end of the line and may have been preceded or accompanied by difficulty of breathing, inability to walk etc. (Refs A and D).

The simple remedy for this kind of dehydration is drinking water and stopping the heat load (i.e. cease working, rest in the shade, etc). It may be necessary in extreme cases such as thermo regulatory failure to arrange artificial 'sweating' -evaporative cooling of the body by wetting the clothes with water; this is very effective in dry deserts though it uses a lot of water.

The simple remedy, however, is not so simple if the dehydration is partly or entirely due to gastro intestinal disorders that have caused water loss through vomiting and/or . diarrhoea. In this case the patient frequently cannot keep water down and the only way to re-hydration is administering an intravenous drip. The speed and effectiveness of this as a remedy borders, to unfamiliar eyes, on the miraculous and a 20 minute transition from unconsciousness to weak joke cracking has been observed in at least one patient. It is advisable therefore, for two or more members of an expedition to be able to insert a saline drip and for appropriate packs to be taken. (Steraflex).

The aim, in normal expedition activities, since your body will be coping with plenty else besides, is thus to maintain full normal water balance. The best guide to this is the frequency and colour of urination; if these are normal then you will be safe. In general "little and often" drinking from your own regularly topped-up water bottle is the best way to achieve this.

In survival situations (Refs A and D) it is permissible to reduce water balance by 1 to 2 litres (i.e. a moderately severe sensation of thirst but not too much impairment of overall efficiency) and then drink at the rate at which sweating is taking place. In this way, every drop of water will be put to

good use and this risk of wastage by possibly excessive drinking followed by too-free urination or sweating will be avoided.

It takes five days or so to acclimatise to a hot climate (i.e. for the thermo regulatory. mechanism to adjust -Ref A). Once this has been achieved, acute awareness of the symptoms of dehydration must be inculcated into the whole expedition team and the need to avoid them accepted. Thirst alone is rarely the most reliable guide to water balance; sometimes thirst will be quenched before full water balance is achieved.

Some typical consumption rates for water are given in the Notes on Fuel, Water and Food (pg. 15). At Annex A tables give water balance requirements on a rest-in-the- shade basis and also expected survival times and walk-out distances on given quantities of water (Ref D).

Sweat contains salt and a lot of sweating will cause salt deficiency unless an appropriate eye is kept on intake. This is best taken as extra table salt with food. This is particularly important during the first week when heat adjustment takes place. Salt tablets are unreliable because they often are not dissolved in the stomach and the gut and pass unchanged in the motions. In some people they also cause vomiting. Table salt is both cheaper and more effective. You will find that even large amounts of salt are very palatable in a hot climate.

### **10.3 GASTRO INTESTINAL DISORDERS**

As with water depletion and heat load disorders, so with gastro-intestinal problems; prevention is better than cure. And as with heat/water balance disorders the subject cannot completely be covered in notes such as these.

**10.3.1 Prevention.** In general, desert conditions are extremely healthy and the most usual places to pick up gastro-intestinal disorders are inhabited areas where hygiene is poor and the flies proliferate. Precautions are obvious, as they are in the conduct of normal camp duties, especially around the 'kitchen'. Thorough washing-up and cleaning of utensils is important also because remnants of food on them will attract flies.

**10.3.2 Treatment.** Most of the agony caused by severe diarrhoea is due to loss of potassium salt from the bowel. Slow-K (Ciba) is a valuable source of additional potassium, as is orange or lemon juice concentrate if you have it available, for instance in tins. If you start getting diarrhoea you should immediately try to stop it, for the fluid loss and potassium loss can be considerable. Several medicaments may be effective. Codeine phosphate 30mg tablets 2 at once and 2 every four hours until you seize up have been shown to be more effective than Lomotil (diphenoxylate hydrochloride) or Imodium (Ioperamide hydrochloride). If you prefer to take Lomotil take 2 tablets at once and one tablet every 6 hours until the diarrhoea is controlled. If you like Imodium take 2 capsules at once and one after each loose stool until the diarrhoea is controlled. Do not take more than 8 capsules a day. Tincture of opium is very effective; 10-20 drops will control even the fiercest diarrhoea but it makes a mess if the container breaks. Kaolin and Kaolin and Morphia are better avoided.

Note: Typhoid and paratyphoid do not as a rule present as diarrhoea but with a fever and usually constipation and a headache and dry cough. There is no virtue in taking prophylactic antibiotics of any kind to try and ward off infection. Entero-vioform should be avoided at all costs. Controlled trials have shown that it makes no difference on the incidence of diarrhoea and in some unfortunate individuals there is severe damage to their nervous system.

**10.3.3 Constipation.** This is a virtually standard problem on desert expeditions mainly due to the small intake of food, low residue diet, lack of roughage, and high water absorption due to high

ambient temperature. Again prevention is vastly preferable to cure. Whilst inclusion of large amounts of tinned fruit in the diet helps, a breakfast cereal such as All Bran is a reliable means of avoiding problems. Dulcolax tablets appear to be a non habit-forming cure.

#### 10.4 STRESS

Little can be said here about this except to remind you firstly that stress will be present and secondly that it can have tangible effects on health even apart from those expected such as mood, irritability, etc. Appetite, digestion, headaches, migraine and extreme fatigue are among those observed as was the resumption of long given-up smoking by some.

#### 10.5 ROUTINE MEDICAL PROBLEMS

Special-to-desert disorders can include:

**10.5.1 Sore Eyes.** Goggles, sunglasses, and ample supplies of eye drops such as Murine should be taken. Irritation due to dust, very dry air and sometimes from infection or sties can occur .

**10.5.2 Colds, Catarrh, Sore Throats.** A frequent complaint in the early stages of a desert expedition. Take plenty of your favourite throat tablets, e.g. Macs, Strepsils.

**10.5.3 Boils and Sties.** Frequently encountered after some weeks in the field. A burst of antibiotics will cure.

**10.5.4 Sunburn.** Despite constant warnings, the average Caucasian is drawn irresistibly and inevitably to at least an initial dose of excessive sunburn. Desert sun has a far higher UV content than European sun due to very clear skies and high sun angle and is also reflected from the light desert surface; both these help achieve this initial ration of pain and peeling with extraordinary speed. Long sleeved shirts and really effective sun oils should be used. Among other effective ultraviolet light barrier creams is Uvistat. It is important to remember that the lips can get very sunburnt and the makers of Uvistat produce a special lipsalve which is effective. If you have got severely burnt an appropriate corticosteroid cream will, if applied early, remove much of the agony.

**10.5.5 Seasickness.** Worth taking precautions against on the Mediterranean ferries in order to preserve the required energy for getting through customs and immigration.

**10.5.6 Burns.** Accidents from cooking stoves or hot exhaust pipes can happen and appropriate medical kit provision is wise.

**10.5.7 Accidents, Aid To Local Population.** Always be prepared for the necessity of helping out at the scene of motor accidents possibly not associated with the expedition. There will always be local population and desert dwellers seeking medical help which even small expeditions are well able to give. The most commonly sought help concerns:

Eye infections -especially in children

Ear infections -" " "

Small cuts and sores that will not heal

Headaches

Fevers -could be Malarial in travellers from the South. Many seek Nivaquin.

An example of a recently used medical kit is at Annex B.



**10.6 REFERENCES**

- A. Exploration Medicine, edited by Edholm and Bacarach, published by John Wright and Sons, Bristol, 1965.
- B. Preservation of Personal Health in Warm Climates, Published by The Ross Institute of Tropical Hygiene, 1973.
- C. Some Notes on Expedition and Mountain Medicine by R N Illingworth, published by Expedition Advisory Centre.
- D. Desert Survival -PAM(AIR)225 published by the Ministry of Defence, 1975.
- E. The Traveller's Health Guide by Dr. Anthony C. Turner, published by Brathay Hall Trust, Cumbria, England, 1978.

## Annex A (Medical and Survival Notes)

**WATER REQUIREMENTS: WATER BALANCE AND SURVIVAL**

(NB Typical normal water consumption rates are given in Notes on Fuel, Water and Food)

**WATER BALANCE -REST CONDITIONS**

The table below is of use when planning the logistics of a situation where maintenance of water balance -and thus full mental and physical efficiency - is required:

**DAILY WATER REQUIREMENTS TO MAINTAIN WATER BALANCE - REST IN SHADE AT ALL TIMES**

Max daily temp °C	Litres per 24 hours
43	5.3
38	2.4
33	1.2
28 and below	1.0

**SURVIVAL/WALK-OUT DISTANCES VS WATER AVAILABLE****DESERT WATER TABLE -DAYS OF EXPECTED SURVIVAL**

Condition	Max daily shade °C	Total available water per man – litres					
		0	1	2	4	10	20
1. Resting in shade at all times	50	2.5	2.5	2.5	3	3.5	4.5
	45	3	3	3.5	4	4.5	7
	40	4.5	5	5.5	6.5	8.5	12
	35	7	8	8.5	10	14	20
	30	9.5	10.5	11.5	13	19	30
	25	11	12	13.5	15.5	22.5	34.5
	20	12	13	14	16.5	23.5	36.5
2. Walking only at night and resting in the shade by day (approx distance walked shown in brackets – kms)	50	0	1	2	4	10	
	45	1(40)	2(40)	2(48)	2.5(56)	3.5(64)	
	40	2(40)	2(40)	2.5(48)	3(56)	3.5(64)	
	35	3(40)	3.5(40)	3.5(48)	4(56)	5(72)	
	30	4.5(48)	5(48)	5(56)	6.5(72)	7.5(88)	
	25	7(65)	7.5(70)	8(78)	9(100)	11(112)	
	20	8.5(83)	9(91)	10(105)	11.5(125)	14(160)	
	9(90)	9.5(98)	10.5(130)	12.5(175)	15.5(225)		

Note the use of the term 'survival' -the person's condition toward the end of the periods indicated would be extremely serious.

Tables based on information in UK Ministry of Defence (RAF) pamphlet PAM(Air)225

-*Desert Survival*. See also *Exploration Medicine* by Edholm and Bacharach, published by John Wright & Sons, Bristol, 1965.

## Annex B (Medical and Survival Notes)

**MEDICAL KIT**

An example of recently used medical kit for a one-man expedition is shown below:

**Medical Kits****Box 1, Steel Ammo Box, rubber seals, 10in x 7in x 3.5in**

250ml Savlon 1 x 3in crepe bandage 5yds  
 3 medicated lint dressings 2 x 3in crepe bandages 4yds  
 4 Steri-strips (pkts of 5 9 disposable syringes & needles  
 suture grips)  
 10 hypodermic syringe  
 Sterile burn glove  
 4 x 2ml ampoules Maxolon (anti-emetic)  
 15 medi-swabs  
 10 x 2ml ampoules Fortral (pain)  
 5 medi-prep swab  
 25 Senokot  
 Murine Eye Drops  
 15gm Cictrin anti-biotic powder in 'puffer'  
 30 tabs Septrin anti-biotic  
 15 tabs Fortral  
 Tetracycline eye ointment  
 5 tabs Dexedrine  
 25 Tabs Paracetamol  
 100 tabs Distalgesic  
 Dixarit/Valium (migraine)  
 Clinical thermometer  
 Misc Elastoplast airstrip\*  
 HP67 magnetic programme cards  
 Tube Brulidine (anti-magnetic storage)  
 16 tabs Magnapen oral penicillin

**Box 2, Steel Ammo Box, rubber seals, 10in x 7in x 3.25in**

100 Lomotil  
 3m plastic adhesive strapping  
 25gm cotton wool  
 50ml 2% tinc iodine (Also for water purification)  
 50gm tube Uvistat  
 100gm Metamucil  
 4 Gillette scalpels  
 Spare clinical thermometer  
 Tablets for dysentery\*\*  
 3 lipsalves.

Books: Exploration Medicine  
 Rost Inst Health in Warm Climates  
 Travellers Guide to Health  
 Desert Survival PAM (air) 225

**Quick-access medicines in personal kit**

In polybag:     Evasun 5 sunoil  
                  Boots insect repellent spray  
                  Murine Eye Drops  
                  Avomine travel sickness tabs  
                  Lomotil  
                  Senokot  
                  Puritabs  
                  Nivaquin

\*\* For amoebic dysentery: either metronidazole (Flagyl) or mepacrine

For diarrhoea: Codeine phosphate 30mg tabs are unsurpassed

\* Have some micropore dressing strips as well (many people are allergic to ordinary zinc oxide dressing strips)

## Section 11: NAVIGATION, MAPS, RESCUE AIDS

### 11.1 CONSTITUENTS

The constituents of effective navigation in desert regions, listed in ascending order from the most fundamental to the most esoteric are:

1. **A meticulous**, even perfectionist, navigator who worships at the altar of Truth rather than the altar of convenient results.
2. **Maps**, a compass and binoculars.
3. **A vehicle** odometer of known accuracy.
4. **A navigation** log.
5. **A theodolite**, accurate time source and appropriate means of calculating astro fixes.
6. **Satellite** navigation equipment.

The ingredients are also listed in order of importance; numbers one through four are necessary for *all* types of navigation in desert regions.

### 11.2 APPLICATION

Navigation methods and equipment requirements will vary according to terrain and whether on or off tarmac or tracks. Type delineation as follows:

**On Tarmac.** Ingredients 1 to 4 above required -though compass will likely not be necessary all the time.

**On Tracks.** Ingredients 1 to 4 above required. Resist the temptation to believe you are on the right track; always monitor your general heading on the compass and cross- check with map.

**Off Tracks.** Cross-Country. For up to 100 miles of not-too-difficult going ingredients 1 to 4 may suffice provided a sun compass or very painstaking use of the magnetic compass is applied (i.e. all readings taken well away from vehicle). For distances greater than this the accumulated possible errors of this kind of navigation really demand ingredients 5 or 6 to achieve independent position fixing once a day. These are generalisations that vary according to the complexity of the terrain, the route taken, the objective to be found and the competence of the navigator .

### 11.3 INGREDIENTS OF DEAD RECKONING NAVIGATION

There is not scope within this course to cover in practical detail advanced forms of desert navigation, use of sun compass, or independent position fixing aids. There remains, however, much that can be applied to enhance general navigation accuracy and the following notes may be of help.

**11.3.1 Navigation Log.** Essential for any map reading or navigation in desert regions -on or off roads or tracks -is the navigation log. The navigation log is physically no more than an appropriately ruled (See Annex A) spiral bound shorthand pad (so that pages fold back on themselves). Its purpose is to record time, odometer readings, headings, bearings of landmarks or any significant navigation feature such as a branch or intersection of a track, a distant village or hill, a well, a vehicle seen from which you may later require help. Apart from being an invaluable record of your journey it has two main applications and a third important one:

*Basis of Estimated Position.* Record from which DR position is deduced -See Annex A.

*Re-Appraisal of Position.* Frequently, when you are on what you think is a well defined track to your planned destination you will find that the track peters out or takes up a heading wildly different from that required. Knowledge of previously encountered branches in the track or landmarks, together with knowledge of how far back down the track they were, can indicate where you may have taken the wrong turning or jumped to the wrong conclusion about your route.

Nothing compares to the alarm and sinking feeling of knowing something has gone wrong with the navigation; a well kept navigation log will keep you out of trouble.

*Rescue.* Noting where other vehicles, villages, settlements or wells were last seen is vital if faced with a sudden accident or breakdown. Feasible walking distances, visibility of rescue flares, decision on whether to go on or go back can be accurately based on a good navigation log.

**11.3.2 Mini Tape Recorder.** Because of the difficulty of writing the navigation log in a bumping vehicle, enroute details can be recorded on pocket tape recorders such as the Olympus Pearlcor, the Philips 0095 or the Sony note-takers. They can be protected from dust by wrapping in a polythene bag with elastic bands. Controls and microphones can still be operated through the polythene. The written log is then transcribed at convenient halts or in the evening.

**11.3.3 Magnetic Compass.** Despite its simplicity the magnetic compass can be misused. Important reminders:

*Aiming.* Use a prismatic or accurately aimable compass, preferably fluid damped. Put the hairline precisely on the objective.

*Ferrous Metal Influences.* Use the compass well away from your vehicle (10 metres). Ensure no other ferrous metal influences -items in your pockets and the most easily forgotten, steel framed spectacles or metal hat-badges.

*Needle Pivot.* A 'sticky' or worn needle pivot can often go unnoticed. When accurately lined up on your objective move your line of sight first left then right by about 3° and check the needle does respond. Re-align your aim and then take your reading. Store your compass where it gets a gentle ride.

*Magnetic Variation.* Variation (the difference between true and Magnetic north) must be applied to all readings. It varies for given areas year to year. Ascertain value before leaving UK; Directorate of Overseas Surveyor sellers of aeronautical maps will know the up to date figures. When you get to your region of operations, the local aerodrome (if there is one) will know the value. If you have a theodolite you will be able to ascertain magnetic variation yourself by reference to (true) star azimuth. (Leave the theodolite on the known azimuth of your last star shot and align the horizontal degrees scale accordingly. Next morning compare theodolite and compass bearings of a given distant object).

*Quartz Watches.* Analogue watches (those with hands) running off a quartz movement generate a quite powerful magnetic field. Insidious and dangerous errors from wrist worn watches affecting hand-held compasses have been found. Whatever your watch, check its effect, remove it if in any doubt.

*Vehicle Mounted Compass.* Despite 'correction magnets', a compass mounted in a vehicle is of dubious if not dangerous reliability for desert navigation. The fascia/windscreen/scuttle area, normally used for mounting a vehicle compass is a region of magnetic turmoil in the vehicle -also randomly affected by electrical services in use, contents gauges etc. to say nothing of the ferrous load on the vehicle. Bump, sway and acceleration errors further increase unreliability and impracticality.

**11.3.4 Sun Compass.** Tantalising to write about since sun compasses are not available to buy. An ex-WW2 Coles, if obtainable, is ideal for desert use, giving on-the-move readings, immune from magnetic errors, accurate to 10. Beware levelling errors when used on vehicles with self-

levelling suspension such as current Range Rovers and some Land Rovers. (For mounting see Notes on Vehicle Modification, Annex B.)

**11.3.5 Distance Measurement.** A trip speedometer, preferably in kilometre calibration (with tenths) is recommended. For vehicles with Smiths speedometers, Smiths will calibrate your instrument on the tyres you propose using if you take your vehicle to their north London factory. It is important to know the percentage error inherent in your vehicle. It is often possible to have this residual error eliminated; Smiths can put you in touch with firms that do the work.

**11.3.6 Dead Reckoning.** Measurement of heading and distance as indicated above are the ingredients of Dead Reckoning navigation. Travel north 10km, then east 10km then south 10km. If you deduce that your starting point is now 10km to the west you have just -if you have not done it before -carried out your first piece of Dead Reckoning (DR) navigation. A log of heading and distance-on-heading can, when plotted geometrically, yield your present position as a bearing and distance from your start point. It can be done on a pocket calculator as well. DR navigation is the basis of the on- and off- tracks methods to be used (see "Application" section above). At Annex A is shown a typical complete navigation log and the subsequent DR plot resulting from it. The extraction of heading and leg (distance-on-heading) will be clear from the diagram -i.e. from Gravity Station 74 the vehicles set off on heading of 105°, the odometer reading being 80.8; this heading was held for 5.8km; next heading was 070°, which was taken up at an odometer reading of 86.6km; that heading was held for 4.3km, etc.

#### **11.4 INDEPENDENT FIXING -ASTRO**

A nightly position fix derived from astro (star) shots and thus independent of any accumulated DR navigation error is highly desirable in any poorly mapped areas, where track alignment is doubtful or in regions away from tracks (see " Application" page 65). It is essential for mapping of any kind and (see "Magnetic Compass", Magnetic Variation, Page 66) is also a means of determining magnetic variation accurately.

Equipment required would be:

- Theodolite (T2 grade -accurate to +/- 1in)
- Tripod (special heavyweight for theodolites)
- Astro tables -almanac and marine sight reduction tables.
- Blank plotting charts 1:5m for appropriate latitudes
- Quartz time Source, calibrated, and SW radio for time check.

Position fixing to better than +/- 300m is feasible with care. Highly recommended is a programmable pocket calculator such as the Hewlett Packard HP67 in which, by use of a magnetic card containing the appropriate programme, completely accurate reduction of the astro shot can be done without the time consuming and error-prone use of tables. Learning the necessary skills (including star identification) for really reliable use of theodolite to produce consistently accurate fixes cannot be done over a weekend. The School of Military Survey course for 'crude' use of a theodolite for desert navigation is two weeks. Practice, taking fixes from precisely known spots, is essential and that, bearing in mind the need for clear night sky in UK with no cloud, makes the total learning time even longer. The equipment listed above will weigh just about 50 lbs and, especially without the HP67, the fixing will be a time consuming process -1-1.5 hours per night minimum on average with a fairly experienced operator. Buying price, new, would be about £3,000 so in most cases hiring or borrowing would be the aim. Ex-RAF bubble sextants are crude, unreliable and randomly inaccurate in desert conditions -Le. heat, dust and vibration -despite reasonable performance at home.

### 11.5 INDEPENDENT FIXING -SATELLITE NAVIGATION

Like astro in that it is independent of accumulated DR errors, satellite navigation, Le. position fixes derived from each of the five US 'Transit' satellites, has exciting possibilities for expedition use. It has special application and enormous potential for advanced navigation or basic mapping off - tracks or in open desert. Operating skills are minimal, fixing is automatic and to accuracies of about +/-100m, size weight and cost are down significantly on theodolite equipment and day /night fixes independent of clear skies are routinely possible. The rate of development of any equipment based on microcomputers is breathtaking and the following comments should be noted as written in Summer 1983 and amended in Spring 1988. Points of operational interest and comments relative to the Magnavox MX4102 and 6102 equipment are:

**11.5.1 Size, Weight, Cost, Current.** About 30cm square and 8cm deep, the MX4102 weighs 5.4kg; the antenna weighs 1.2kg and is 87cm long. Cost is about £2000 and power consumption 12-15 watts off 10-30 volts DC. It has been run for 24 hours off a static Range Rover (without battery charging); battery voltage dropped to 10.4v but this was enough to enable the engine to be started easily. Use overnight (say 14 hours) or during an evening halt in the field appears feasible off a good 57 amp. hr. battery.

**11.5.2 Inputs.** Required user inputs are:

*Latitude/longitude* to nearest degree GMT to nearest minute.

*Antenna height* above sea level -as accurately as possible (fix error is three times antenna height error, i.e. a 50m heighting error will cause a 150m fix position error). The 6102 has its own heighting capsule.

**11.5.3 Output and Time-in-Position Requirement.** A transmitting satellite is received from 'rising' to 'setting' a time of 12-16 minutes. Although in marine applications on-the- move fixing can be done where constant heading and speed are held, overland use demands the vehicle be stationary for this time. Once the MX4102/6102 has been on and receiving (even on the move) it can forecast the time-of -rise of the next 16 satellite passes. With this knowledge, the vehicle can then be stopped when a satellite is due and a fix taken. The MX4102/6102 has to be on in order that it can calculate the forecast passes so there is a case for keeping it switched on throughout the day and sufficient of the evening for it to forecast the next morning passes. It's memory is non-volatile for more than 10 hours so it will retain information overnight. The forecast period covers up to 22 hours so if, for any reason, the set has to be switched off, a note of satellite pass times before doing so will still retain the required information for the day. Output from fixes is latitude/longitude in degrees, minutes and hundredths of a minute; there is also a readout on time of fix and its quality or reason for rejection.

**11.5.4 Antenna Position.** Despite the ideal obstruction-free vertical mounting requirements laid down by Magnavox (15ft from vertical obstacles, 3ft above nearest flat surface), the antenna seems remarkably tolerant of mounting position and in fact pulled in good signals whilst lying on the metal floor of a pickup in motion on the road. In a (soft-top) Range Rover, the aerial placed vertically on the passenger seat worked well. The point is made since ostentatious or peculiar equipment of this kind invariably causes suspicion among border or other police overseas and there is much to be said for keeping most of the equipment out of sight. A dual-position mounting would be sensible -a proper , exposed vertical mounting being used in the open desert away from population.

**11.5.5 Heighting.** A potential problem for the 4102 in remote and poorly mapped regions is heighting. Accurate knowledge of antenna height is important for accurate fixes. One way round this is the use of a barometer altimeter or aneroid which can be 'anchored' at surveyed points before leaving well-mapped areas and used thereafter to supply relative heights from which antenna height may be deduced.



**11.5.6 Compass Heading and Speed Sensor Attachments.** The MX4102/6102 has the MX35 flux gate magnetic compass attachment available -a means of sensing the magnetic field without any moving parts and displaying it on the alpha-numeric read-out. The device has the means of *automatically* making corrections for magnetic variation and deviation. Combined with a special gearbox-mounted speed sensor and properly calibrated full dead reckoning waypoint-homing facility is available.

**11.5.7 Mounting.** Because its design specification is to the relatively small environmental temperature band of 0 to +50°C, great care must be taken to keep the equipment out of direct sunlight and well ventilated. Thus the desirable mounting under the windscreen for the on-the-move reading (e.g. with the compass attachment) is ruled out. In 1987 failure through excessive ambient (48°C) and acquired temperatures (circa 65°C) was experienced on 6102.

## 11.6 OTHER AIDS

**Dibs-Mirror.** A large, -say 5in x 7in -flat, forward facing mirror universally mounted from the windscreen pillar of the vehicle to reflect the sun as a spot of light onto the ground 30-50m ahead can be of great value off-tracks in the desert as a terrain slope indicator and a direction-of-travel marker. Its most important use is the former. In conditions of strong high sun on the smooth unbroken surface of virgin sand it is possible to drive over the edge of a dune or into a dune base without seeing it. The spot of light gives a point of focus on the sand. The spot disappearing or moving up, left or right, will give advance indication of a dune edge or slope change. As a heading marker, once the direction of travel has been established, the spot of light can be adjusted to lie dead ahead and then followed. By the laws of optics applying to reflected light, deviation of the vehicle from the desired course by 5° causes the light to move through 100. (due to sun movement, of course, re-alignment of the beam must be carried out every 15 minutes). See Annex B.

**Binoculars.** Binoculars are invaluable in the desert as distances and shapes are very deceptive. There is plenty of light so large optics (S0mm) are not necessary. Light-weight 10x30 binoculars are ideal.

## 11.7 GOLDEN RULE

Jumping to conclusions is the most common source of inaccurate desert navigation. Do not mask insecurity with arrogance by fitting the 'facts' to your hopes or presumptions about position. All the evidence must be weighed, an open mind kept, the conflicting evidence must be disposed of before the final conclusions are drawn. Was the hill 20kms back really that indicated on the map? Were the dunes at the 2 o'clock position the ones mapped? Is the track alignment on the map accurate? You must make a case for establishing a position -rather as a lawyer would -since all the 'witnesses' may not be what they seem and all evidence must be weighed. An open, analytical mind and a readiness to face facts is vital.

## 11.8 EQUIPMENT

See Annex C for equipment list.

## 11.9 MAPS AND GUIDES

**TYPES AND SOURCES.** Mapping in the UK and Europe is of an extremely high standard and the first-time desert traveller should be prepared for a shock regarding map coverage, accuracy, scale and availability. For the African Sahara use:

**Michelin Maps -Sheet 153 and 154.** Scale 1:4m, an excellent planning/logistics map. Reliable in most regions, provides information on regularly used roads and tracks plus details of facilities -including fuel, water, rest houses etc -along them. Essential for any Saharan traveller. Accuracy varies according to regions -e.g. not good in Mali. After being unavailable for 7 years, a new sheet 153 is now out (1983).

**Topographic Map, Series 2201.** Scale 1:2m, a reasonably accurate map series for broad-based planning. Published by Ministry of Defence, available through map sellers such as Stanfords in Long Acre. All Africa covered.

**Topographical Map, 1:1m 1:500,000 and 1:200,000.** Coverage and availability problems. Ministry of Defence maps (GSGS series 1301 and 1404) cover most areas but with varying reliability; many sheets are very old (40 years) and often inaccurate. The French Institut Geographique (IGN) publish maps of old French colonial areas in Africa and, in the regions covered, are generally the best available. Coverage at 1:500,000 is limited and at 1:200,000 even more so. 1:200,000 maps are sometimes available only through the countries concerned (e.g. Algeria; the others are best obtained by going to the IGN shop in Paris (107 rue Boetie, 5 minutes walk from the Arc de Triomphe).

**Astro Plotting Maps.** 1:500,000 skeleton plotting charts GSGS series 4700 are useful for plotting astro shots.

**'Algerie'.** Also in French by Hachette. Very detailed, very good. One of Hachette's Guide Bleu series.

**'Sahara Handbook'** by Simon and Jan Glen (Lascelles).

**'Guide du Sahara'.** Published (in French) by Hachette and available from The European Bookshop, 4 Regent Place, off Regent Street, this is an invaluable guide book with much detailed information on tracks, towns and villages. Route and sketch maps provided.

Source of maps for desert regions outside the Sahara are less easily categorised though the start point would again be the Ministry of Defence/Directorate of Overseas Survey maps available through Stanfords or DOS.

## 11.10 RESCUE AIDS

**11.10.1 Pre-Planning.** Consider who the call for help will be aimed at -aircraft, other travellers, a distant village, a radio link, a regular convoy on a given route. Consider also the requirements of day or night recognition. Consider intervehicle communication. Consider leaving details of your route, supplies and actions-in-the-event-of-emergency with local authorities. Evolve a standard procedure for timings of rescue calls, discharge of flares, etc so as to ensure the appropriate agency will be looking and listening at that time.

**11.10.2 Radio.** Radio is a glib solution to any rescue problem. In practice it is not easy. Cost equipment, qualified CV operators with appropriate licenses, allocation and clearance for frequencies by UK and foreign countries, setting up of an appropriate base station and most important of all, setting up rescue facilities that can be mobilised in the event of need -all these conspire in most cases to render radio impractical for cost/bureaucratic reasons.

**11.10.3 Rescue Beacons (Radio), Sarsat.** Three satellites now orbit the earth picking up radio distress transmissions. The Burndep BE522 rescue beacon is made principally for users of sea-going craft and is a transmitter tuned to both the VHF (121.5 Mhz) and UHF (243 Mhz) international distress frequencies. It is a cylinder about 2 inches in diameter and 16 inches long weighing about 18oz; it has self-contained long life batteries. When activated, the radio transmissions are picked up by one of the orbiting SARSAT (Search and Rescue SA Tellite) which relays and approximate (10km) position fix to the rescue co-ordination centre at Toulouse. The satellite orbits roughly every 80 minutes and repeated signals will result in Toulouse alerting appropriate national authorities. What happens then and how long it takes cannot be guaranteed but the alert is a worthwhile precautionary capability. At the time of writing (1988) the retail cost of a

BE522 is about £135. It (and other more exotic beacons) is made by Burndept Electronics, Tom Cribb Road, Thamesmead, London SE28 OBH (Tel. 01-316 4477).

**11.10.4 Simple Rescue Aids.** Common sense and a browse round a good ship's chandlers will yield the kind of practical equipment to be taken on expeditions:

*Heliographs* -very effective vehicle-to-vehicle and ground-to-air. See Annex D.

*Smoke flares/rockets.* A number of lightweight smoke flares/rockets are available. Select a fluorescent green smoke to show up best against the desert. Take a few really high- flying distress rockets or parachute flares.

*Whistles.* Loud 'referee' whistles are light and more efficient than the voice for attracting attention.

*Fluorescent panels.* Bright green fluorescent fabric panels can sometimes be obtained and aid air to ground recognition.

*Air-ground rescue codes.* See Annex E.

**11.10.5 Scale of Equipment.** Small heliographs, whistles, torches and a Mini-flare pack should, where possible, be issued to each member of a team. Make rules that if lost, flares will be discharged only on the hour and half hour; that way, seekers can be alert at the right time.

## Annex A (Navigation Notes)

## EXAMPLE OF DR LOG PLOTTED OUT TO GIVE TRAVERSE

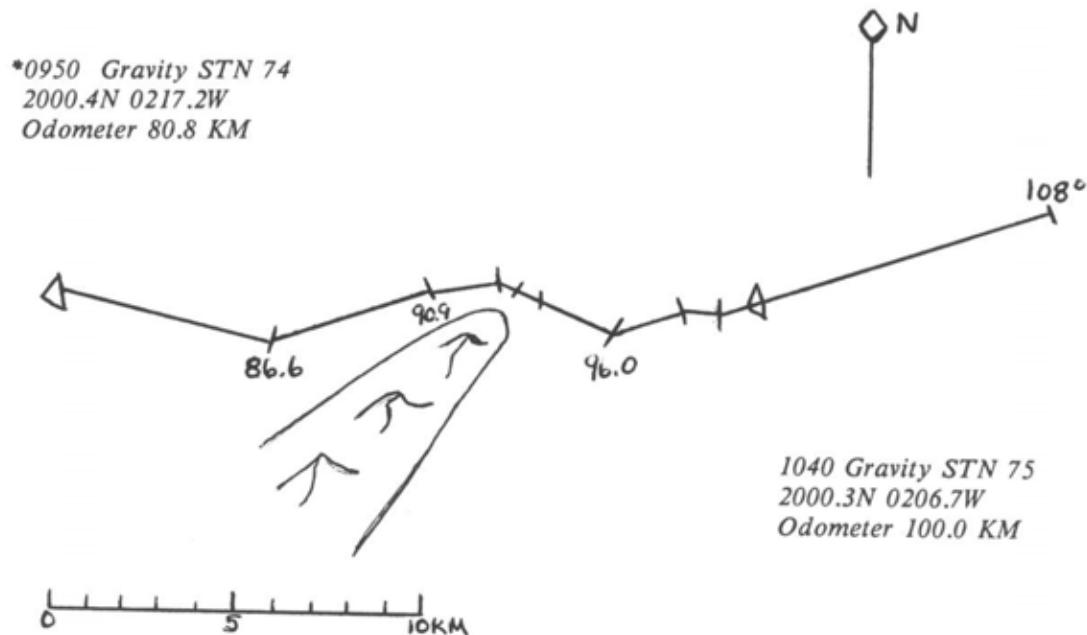

## EXAMPLE OF DR LOG RECORDINGS

The log for part of 17 Feb 75 is shown below, complete with preliminary calculations to set up and check the sun compass:

**CAMP 24 -17 FED 75.** Lat  $19^{\circ} 56.5N$ , Long  $03^{\circ} 02.5W$ .  
Speedo reading 5913

Sun compass into: Mid longitude for days run  $2^{\circ} 15W$ .  
Divided by 15 = -9 minute (West, therefore negative)  
Equation of time = -13 minutes  
Local Apparent Time (LA T) = GMT -22 minutes  
Add 7.5 minutes for running setting  
= GMT -14.5 minutes (set on vehicle Clock).

Sun compass setting check =  $226^{\circ}$   
Magnetic bearing =  $232.5^{\circ}$   
Variation  $6.25^{\circ}$  confirmed.

Desired Courses for day:  $083^{\circ}/38$  km  
 $092^{\circ}/47$  km  
 $071^{\circ}/30$  km

Time	Leg (km)	Obervation (Zone)	Hdg (Deg)	Trip Speedo
0735	6.4	0715 LAT set	067	0.0
0745	13.5	Pass W. end of small dune chain 0730 LAT set. Skirting N edge of dune chain.	083	4.2 6.4
0752		Main very long chain north 3-5 km Distant dunes 1-2 o'c ERIGAT EL THOZLANE Rippled sand sheet 40 kph	11.6	
0800	20.1	0745 LAT set. <b>Gravity Station 71.</b> 1958.7N,0251.4W	083	19.9
0815		Wind NE 16 kts. Temp 15°C 0800 LTA set		
0825		Western end os small E-W dune chain at 9 o'c 1 1/2 km		30.2
0828		ERIGAT EL RHOZLANE dunes extend from 3 o'c to 12 o'c. We should skirt N end.		
0830		0815 LAT set		
0835		<b>Gravity Station 72.</b> 2000N, 0240.4W	083	40.0
15.8				
0845		0830 LAT set. RHOZLANE still on rt. Extends further than map shows. Wind 21 kts. Temp 18oC. Feels cold. Dunes to N disappeared. RHOZLANE now parallel to hdg 1 km on our rt.		
0855		Dune line 2 km in 9 o'c posn running 080-260°. Gravel patches. Scrub grass		49.1
0900		0845 LAT set		
0905		RHOZLANE now petering out and clearing to south. Small dune line ahead aligned 080-260. We go right of it.	100	55.8
4.2				
0912		RHOZLANE ended -clear to south now <b>Gravity Station 73.</b> 2000.7N 0229.1W		57.0
0915		0900 LAT set. New hdg	095	60.0
10.0				
0930		Very distant dunes 1 o'c. Wind 19-23 kts. Sand blowing. 0915 LAT set. Dunes now from 12 1/2 o'c to 2 o'c running about 070°		
0936		Aiming between dunes encroaching on right and new dunes at 11 o'c.	081	70.0
5.3				
0942		0930 LAT set. Dunes on right have petered out but persist on left 2 km away heading 080/260. Rolling rippled sand sheet. Easy top gear.	095	75.3
5.5				

---

0950	Gravity Station 74. 2000.4N 0217.2W	105	80.8
5.8			
1010	1000 LAT set. Dune line to rt running 075/255	070	86.6
4.3			
1025		080	90.9
1.8			
	Through dune gap	115	92.7
.8			
	Mirror dunes	105	93.5
.7			
		115	94.2
1.8			
1035	Now in wide dune valley 7 km wide	070	96.0
1.8			
	Small dune line -go right	096	97.8
1.0			
		070	98.8
1.2			
1040	<b>Gravity Station 75.</b> 2000.3N 0206.7W	070	100.0
8.0			
1047	1030 LAT set. Wind 28 kts. 23°C Going in dune corridor. Occasional rocky patches.		

Annex B (Navigation Notes)

PRINCIPLE OF 'DIBS' MIRROR

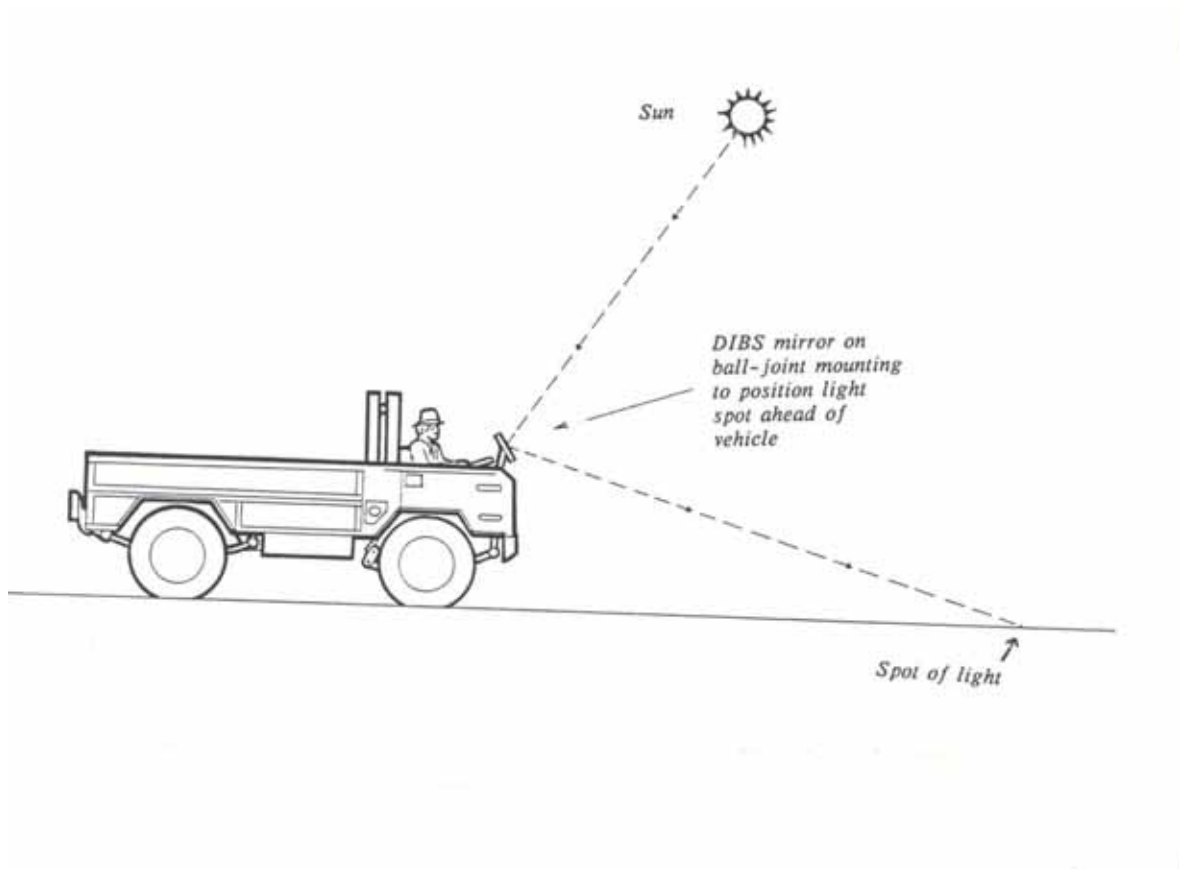

*Optimum mirror to use of DIBS application is about 6in x 8in and must be flat: a convex mirror will not project a light spot.*

**Annex C (Navigation Notes)****EQUIPMENT LIST: NAVIGATION KIT AND MAPS**

Example of equipment used on small expedition to off-tracks regions of Algeria where mapping was carried out.

**In Samsonite Briefcase 12 x 18 x 4.5:**

Spiral bound notebook for DR log  
 Star planispheres  
 Ruler (mm) BBCWorld Service pgm sched  
 Douglas Protractor and spare Nautical Almanac 1979  
 Compasses and dividers  
 Sight Reduction Tables (Naut) ( 15° -30°)  
 Pencils, 2H, 3H, 4H  
 Rubber Astro forms and instructions  
 Stopwatch  
 Hewlett Packard HP 67 and magnetic programme cards  
 Spare gnomons/cursor for sun compass  
 Spare mag programmes (stored in Med Kit steelboxes)  
 Philips 0095 pocket tape recorder and spare Mallory batt notes;  
 HP67 instr book and keying noted; 12vDC recharger  
 Spare Wild Theodolite instr book  
 HP67 spare batts, 3  
 Rover petrol log

**Maps: 1:2m Series 2201      Sheets 7, 2 and 3**

**1:2m IGN or Series 1301.** Sheets NH30 Bechar, NH31 Oargla, NG29-30 Erg Chech, NG31 in Salah (1301), NG32 Djanet (IaN) and Fort Charlet (1301), NF30 Taoudenni, NF31 Fort Lapperine (and 1 spare), NF32 in Azoua, NE30 Tombouctou, NE31 Kidal.

**1:500,000 IGN.** NG32: NE, NW (Illizi); SE (Djanet); SW (Ft Gardel). NG31: NE (Amguid). NF31: NE (Tamanrasset).

**1:250,000 Series P502 -old.** 8 sheets roughly NE from Tamanrasset.

**GSGS 4700 Skeleton Plotting Charts for Astro.** Sheets No 12 (1920-2200N); 13 (2130-2410N); 14 (2340-2620N); 15 (2550-2830N); 16 (2800-3040N).

**Michelin Road Maps.** Sheets 153 Africa N & W, 1 :4m; 901 France 1: 1 m; 172 Algerie/Tunisie 1:1m; 169 Maroc 1:1m.

**Nav Kit not in briefcase:**

Wild T2 theodolite in transit case  
 Wild T2 lighting set and spare batteries  
 Wild T2 GST20 tripod  
 Sun Compass  
 Magnetic compass MK III prismatic, fluid damped  
 Philips recorder spare mini-cassettes  
 Binoculars 10 x 30



Heliograph and whistle

Sony ICF5900W shortwave radio with crystal marker.

Hachette's Guide du Sahara (obtained later en route)

**SIMPLE HELIOGRAPH -CONSTRUCTION AND USE**

*If not readily available from camping shops or ships chandlers, a heliograph can be made from a small ladies mirror or a stainless steel shaving mirror.*

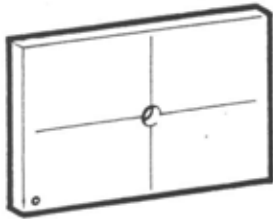

**CONSTRUCTION**

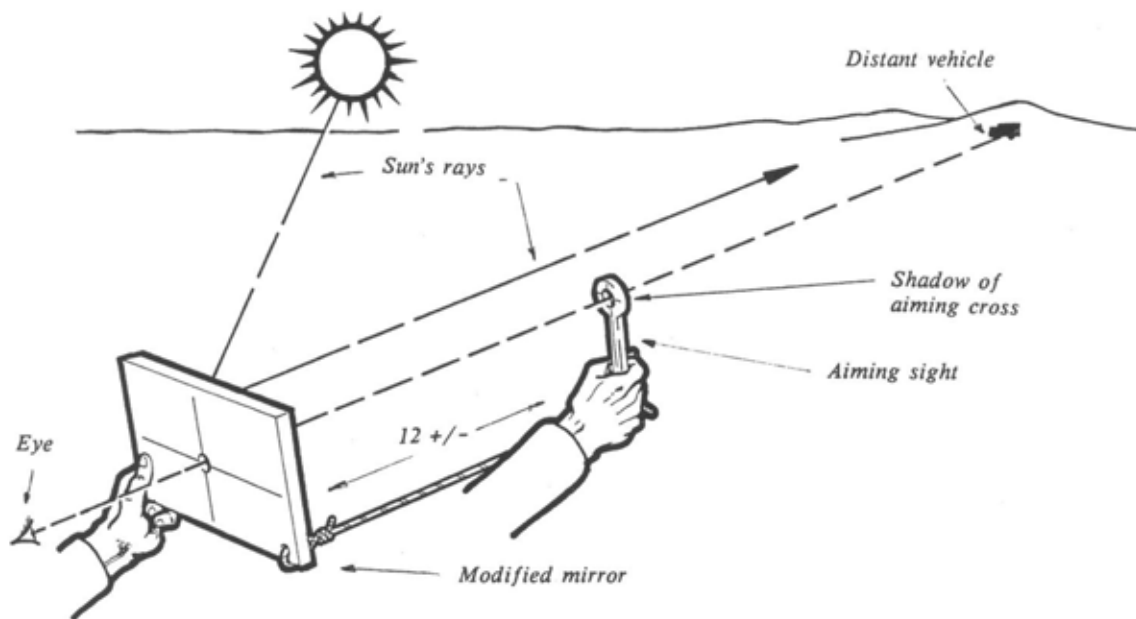
*3in x 4in mirror. If steel, bore central hole for aiming. If glass, scrape away silvering on back. Paint or scribe aiming cross on front face. In use, adjust angle so that sun and shadow of aiming cross fall on aperture of aiming sight.*

**USE**

Annex E (Navigation, Rescue Aid Notes)

INTERNATIONAL GROUND / AIR CODE

Key	Code	Visual Body Signals
1. Require doctor—serious injuries	I	 <p>Affirmative (Yes) Wave cloth or hand up and down slowly with side of body facing aircraft</p>
2. Require medical supplies	II	
3. Unable to proceed	X	
4. Require food and water	F	
5. Require firearms and ammunition	V	
6. Require map and compass	□	
7. Require signal lamp with battery and radio	!	
8. Indicate direction to proceed	↙	
9. Am proceeding in this direction	→	
10. Will attempt take off	▷	
11. Aircraft seriously damaged	⌊	
12. Probably safe to land here	△	
13. Require fuel and oil	L	
14. All well	LL	
15. No	N	
16. Yes	Y	
17. Not understood	JL	
18. Require engineer	W	 <p>Pick us up - Plane abandoned Hold arms across head to form a V</p>

## **Section 12: SCIENTIFIC INSTITUTES OF DESERT STUDIES**

### **ALGERIA**

Centre National de Recherches sur les Zones Arides (CNRZA), Universite d' Alger , 2 rue Didouche Mourad, Algiers.

### **ARGENTINA**

Instituto Argentino de Investigaciones de las Zonas Aridas (IADIZA), Casilla de Correos 507, 5500 Mendoza

### **AUSTRALIA**

Division of Land Resources Management, Rangelands Program at Deniliquin and Alice Springs, Riverina Laboratory, Private Mail Bag, Deniliquin, New South Wales. Alice Springs Field centre: P O. Box 77, Alice Springs, Northern Territory , 5750.

### **BOTSWANA**

Veld Products Research, P O Box 2020, Gaborne, Botswana

### **CHILE**

Centro de Estudios Zonas Aridas, Universidad de Chile, La Serena

### **EGYPT**

Desert Institute, El Matariya, Cairo

### **FRANCE**

Office de la Recherche Scientifique et Technique Outre-Mer (ORSTOM), 24, rue Bayard, 75008 Paris

### **INDIA**

Central Arid Zone Research Institute, Headquarters: Jodhpur, Rajasthan, India

International Crops Research Institute for the Semi-Arid Tropics (ICRISA T), Patancheru PO., Andhra Pradesh, India 502 324.

### **IRAN**

Arid Lands Ecology Bureau, P.O. Box 1430, Tehran

### **ISRAEL**

Applied Research Institute, Ben-Gurion University of the Negev, PO Box 1025, Beer-Sheva 84110, Israel

### **JAPAN**

Sand Dune Research Institute, 1390, Hamasaka, Tot tori, Japan 680

### **MEXICO**

Centro Nacional de Investigacion par el Desarrollo de Zonas Aridas (CNIZA), Buenavista, Saltillo, Coahuila, and Instituto de Investigacion de las Zonas Deserticas, Plaza de Fundadores, San Luis Potosi, S.L.P ., Mexico

### **NAMIBIA (SOUTH WEST AFRICA)**

Desert Ecological Research Unit of the Council for Scientific and Industrial Research, Namib Desert Research Station, P .O. Box 953, Walvis Bay, Namibia 9190

**PERU**

Centro de Investigaciones de Zonas Aridas (CIZA), Apartado 330y 456, Lima

**SAUDI ARABIA**

Institute of Meteorology and Arid Lands Studies, P .O. Box 1540, Jeddah

**SYRIA .**

Arab Center for the Studies of Arid Zones and Dry Lands (ACSAD), P .O. Box 2440, Damascus

International Centre for Agricultural Research in the Dry Areas (ICARDA), Aleppo.

**TUNISIA**

Institut des Regions Arides de Tunisie, El Fje -Medenine, Tunisie

**U.K.**

Overseas Development and Natural Resources Institute (ODNRI), Central A venue, Chatham Maritime, Chatham, Kent ME4 4TB

Survey of Economic Plants for Arid and Semi-Arid Tropics (SEPASAT), Royal Botanic Gardens, Kew, Richmond, Surrey

**U.S.A.**

Arid Land Ecosystems Improvement, Agricultural research Service, US Department of Agriculture, 2000 E Allen Road, Tucson, Arizona 85719

Arizona-Sonora Desert Museum, P .O. Box 5607, Tucson, Arizona 85703

Chihuahuan Desert Research Institute, P.O. Box 1334, Alpine, Texas 79830

Desert Botanical Garden, P .O. Box 5415, Phoenix, Arizona 85010

Desert Research Institute, 7010 El Barcho, Sparks, Nevada 89431

Dry Lands Research Institute, c/o University of California, Riverside, California 92502

International Center for Arid and Semi-Arid Land Studies (ICASALS), Box 4620, Texas Tech University, Lubbock, Texas 79409

Philip L. Boyd Desert Research Center, P .O. Box 480, Palm Desert, California 92260

U.S. Water Conservation Laboratory, Agricultural Research Service (USDA), 4331 E. Broadway, Phoenix, Arizona 85040

University of Arizona, Office of Arid Lands Studies (OALS), 845 North Park A venue, Tucson, Arizona 85719

**USSR**

Desert Research Institute, 744000 Ashkhabad, sad Keshi, Turkmen S.S.R. Academy of Sciences

**SECTION 13: DESERT BIBLIOGRAPHY**

- BONYTHON, C.W. (1980) *Walking the Simpson Desert*. Rigby, London
- CLOUDSLEY-THOMPSON, I.L. (1975) *Desert Travel and Research*. Institute of Biology, London
- DAVIDSON, ROBYN (1980) *Tracks*. Jonathan Cape, London
- DAY, P R (1982) "Outback '80" Report of the Joint British Australian Trans-Australia Expedition 1980 (RGS Report 978)
- DUNN, G. (1976) "The Working of a Sun Compass". *Geographical Magazine* 48:647
- GLEN, S. & J. (1980) *Sahara Handbook*. Roger Lascelles, 16 Holland Park Gardens, London W 14 8DY
- HALL, D.N. (1979) *Expedition Navigation*. Royal Geographical Society, London
- HILLABY, J. (1964) *Journey to the Jade Sea*. Constable, London
- JACKSON, I. (1982) *The Four Wheel Drive Book*. Gentry Books, London
- McELDUFF, C. (1975) *Trans Africa Motoring*. Wilton House Gentry, London
- MELVILLE, K.E.M. (1980) *Stay Alive in the Desert*. Roger Lascelles, London
- MOORHEAD, A (1974) *The Fearful Void*. Hodder & Stoughton, London
- MORGAN-GRENVILLE, G.W. (1974) *Cruising the Sahara*. David and Charles, Newton Abbott, Devon
- PAINE, B. (1976) *The Green Centre*. BBC and Andre Deutsch, London
- SAUNDERS, M (1970) *Administrative and Technical Report of the British Air Mountains Expedition (Niger) 1969-1970*. (RGS Report No.283)
- SHEPPARD, T (1976) *Report on the Joint Services West East Sahara Expedition 1975* (RGS Report No.313)
- SHEPPARD, T (1980) *Desert Course Notes*. Royal Geographical Society, London
- SLA VIN, K & I, and MACKIE, G.(1981) *Land-Rover: the unbeatable 4x4*. Gentry books, London
- STEVENS, V. & I. (1978) *Algeria and the Sahara*. Constable, London
- TENCH, R. (1978) *Forbidden Sands*. John Murray, London
- THESIGER, W. (1959) *Arabian Sands*. Longmans, London
- WINSER, N. (1974) *Report of the Polytechnic of London West Africa and Sahara Expedition 1973* (RGS Report No.573)